

Modicon TM3

Safety Modules

Hardware Guide

03/2015



The information provided in this documentation contains general descriptions and/or technical characteristics of the performance of the products contained herein. This documentation is not intended as a substitute for and is not to be used for determining suitability or reliability of these products for specific user applications. It is the duty of any such user or integrator to perform the appropriate and complete risk analysis, evaluation and testing of the products with respect to the relevant specific application or use thereof. Neither Schneider Electric nor any of its affiliates or subsidiaries shall be responsible or liable for misuse of the information contained herein. If you have any suggestions for improvements or amendments or have found errors in this publication, please notify us.

No part of this document may be reproduced in any form or by any means, electronic or mechanical, including photocopying, without express written permission of Schneider Electric.

All pertinent state, regional, and local safety regulations must be observed when installing and using this product. For reasons of safety and to help ensure compliance with documented system data, only the manufacturer should perform repairs to components.

When devices are used for applications with technical safety requirements, the relevant instructions must be followed.

Failure to use Schneider Electric software or approved software with our hardware products may result in injury, harm, or improper operating results.

Failure to observe this information can result in injury or equipment damage.

© 2015 Schneider Electric. All rights reserved.

Table of Contents



	Safety Information	5
	About the Book.	7
Part I	TM3 Safety General Overview	13
Chapter 1	TM3 Safety Modules Description	15
1.1	Modules and Accessories	16
	General Description	17
	Physical Description	21
1.2	Safety Applications Sequential Behavior	23
	One Channel Application	24
	Two Channel Application	27
	Safety-Mat Application	31
Chapter 2	TM3 Safety Modules Installation	33
2.1	TM3 Safety General Rules for Implementing	34
	Environmental Characteristics	35
	Certifications and Standards	38
2.2	TM3 Safety Module Installation	39
	Installation and Maintenance Requirements	40
	Installation Guidelines	43
	Top Hat Section Rail (DIN rail)	44
	Assembling a Module to a Controller or Receiver Module	48
	Disassembling a Module from a Controller or Receiver Module	50
	Mounting a TM3 Safety Module Directly on a Panel Surface	51
2.3	TM3 Safety Electrical Requirements	52
	Wiring Best Practices	53
	DC Power Supply Characteristics	59
Part II	TM3 Safety Modules	61
Chapter 3	TM3SAC5R / TM3SAC5RG Module, 1 Function Cat3 ..	63
	TM3SAC5R / TM3SAC5RG Presentation	64
	TM3SAC5R / TM3SAC5RG Characteristics	66
	TM3SAC5R / TM3SAC5RG Wiring Diagram	69
Chapter 4	TM3SAF5R / TM3SAF5RG Module, 1 Function Cat4 ..	73
	TM3SAF5R / TM3SAF5RG Presentation	74
	TM3SAF5R / TM3SAF5RG Characteristics	76
	TM3SAF5R / TM3SAF5RG Wiring Diagram	79

Chapter 5	TM3SAFL5R / TM3SAFL5RG Module, 2 Functions	
	Cat3	83
	TM3SAFL5R / TM3SAFL5RG Presentation	84
	TM3SAFL5R / TM3SAFL5RG Characteristics	86
	TM3SAFL5R / TM3SAFL5RG Wiring Diagram	90
Chapter 6	TM3SAK6R / TM3SAK6RG Module, 3 Functions Cat4	95
	TM3SAK6R / TM3SAK6RG Presentation	96
	TM3SAK6R / TM3SAK6RG Characteristics	99
	TM3SAK6R / TM3SAK6RG Wiring Diagram	103
Glossary	111
Index	113

Safety Information



Important Information

NOTICE

Read these instructions carefully, and look at the equipment to become familiar with the device before trying to install, operate, or maintain it. The following special messages may appear throughout this documentation or on the equipment to warn of potential hazards or to call attention to information that clarifies or simplifies a procedure.



The addition of this symbol to a “Danger” or “Warning” safety label indicates that an electrical hazard exists which will result in personal injury if the instructions are not followed.



This is the safety alert symbol. It is used to alert you to potential personal injury hazards. Obey all safety messages that follow this symbol to avoid possible injury or death.

DANGER

DANGER indicates a hazardous situation which, if not avoided, **will result in** death or serious injury.

WARNING

WARNING indicates a hazardous situation which, if not avoided, **could result in** death or serious injury.

CAUTION

CAUTION indicates a hazardous situation which, if not avoided, **could result in** minor or moderate injury.

NOTICE

NOTICE is used to address practices not related to physical injury.

PLEASE NOTE

Electrical equipment should be installed, operated, serviced, and maintained only by qualified personnel. No responsibility is assumed by Schneider Electric for any consequences arising out of the use of this material.

A qualified person is one who has skills and knowledge related to the construction and operation of electrical equipment and its installation, and has received safety training to recognize and avoid the hazards involved.

About the Book



At a Glance

Document Scope

This guide describes the hardware implementation of TM3 safety modules. It provides the parts description, characteristics, wiring diagrams, and installation details for TM3 safety modules.

Validity Note

The information in this manual is applicable **only** for TM3 safety modules.

This document has been updated with the release of SoMachine V4.1 SP1.

This document has been updated with the release of SoMachine Basic V1.3 SP1.

The technical characteristics of the devices described in this document also appear online. To access this information online:

Step	Action
1	Go to the Schneider Electric home page www.schneider-electric.com .
2	In the Search box type the reference of a product or the name of a product range. <ul style="list-style-type: none">• Do not include blank spaces in the reference or product range.• To get information on grouping similar modules, use asterisks (*).
3	If you entered a reference, go to the Product Datasheets search results and click on the reference that interests you. If you entered the name of a product range, go to the Product Ranges search results and click on the product range that interests you.
4	If more than one reference appears in the Products search results, click on the reference that interests you.
5	Depending on the size of your screen, you may need to scroll down to see the data sheet.
6	To save or print a data sheet as a .pdf file, click Download XXX product datasheet .

The characteristics that are presented in this manual should be the same as those characteristics that appear online. In line with our policy of constant improvement, we may revise content over time to improve clarity and accuracy. If you see a difference between the manual and online information, use the online information as your reference.

Related Documents

Title of Documentation	Reference Number
Modicon TM3 Modules Configuration - Programming Guide (SoMachine)	EIO0000001402 (ENG) EIO0000001403 (FRA) EIO0000001404 (GER) EIO0000001405 (SPA) EIO0000001406 (ITA) EIO0000001407 (CHS)
Modicon TM3 Modules Configuration - Programming Guide (SoMachine Basic)	EIO0000001396 (ENG) EIO0000001397 (FRA) EIO0000001398 (GER) EIO0000001399 (SPA) EIO0000001400 (ITA) EIO0000001401 (CHS) EIO0000001374 (POR) EIO0000001375 (TUR)
Modicon M221 Logic Controller - Hardware Guide	EIO0000001384 (ENG) EIO0000001385 (FRA) EIO0000001386 (GER) EIO0000001387 (SPA) EIO0000001388 (ITA) EIO0000001389 (CHS) EIO0000001370 (POR) EIO0000001371 (TUR)
Modicon M241 Logic Controller - Hardware Guide	EIO0000001456 (ENG) EIO0000001457 (FRA) EIO0000001458 (GER) EIO0000001459 (SPA) EIO0000001460 (ITA) EIO0000001461 (CHS)
Modicon M251 Logic Controller - Hardware Guide	EIO0000001486 (ENG) EIO0000001487 (FRA) EIO0000001488 (GER) EIO0000001489 (SPA) EIO0000001490 (ITA) EIO0000001491 (CHS)
TM3SAC5R TM3 Safety Module Instruction Sheet	EAV48222
TM3SAF5R TM3 Safety Module Instruction Sheet	EAV48224

Title of Documentation	Reference Number
TM3SAFL5R TM3 Safety Module Instruction Sheet	EAV48225
TM3SAK6R TM3 Safety Module Instruction Sheet	EAV48226

You can download these technical publications and other technical information from our website at www.schneider-electric.com.

Product Related Information



DANGER

HAZARD OF ELECTRIC SHOCK, EXPLOSION OR ARC FLASH

- Disconnect all power from all equipment including connected devices prior to removing any covers or doors, or installing or removing any accessories, hardware, cables, or wires except under the specific conditions specified in the appropriate hardware guide for this equipment.
- Always use a properly rated voltage sensing device to confirm the power is off where and when indicated.
- Replace and secure all covers, accessories, hardware, cables, and wires and confirm that a proper ground connection exists before applying power to the unit.
- Use only the specified voltage when operating this equipment and any associated products.

Failure to follow these instructions will result in death or serious injury.

This equipment has been designed to operate outside of any hazardous location. Only install this equipment in zones known to be free of a hazardous atmosphere.

DANGER

POTENTIAL FOR EXPLOSION

Install and use this equipment in non-hazardous locations only.

Failure to follow these instructions will result in death or serious injury.

WARNING

LOSS OF CONTROL

- The designer of any control scheme must consider the potential failure modes of control paths and, for certain critical control functions, provide a means to achieve a safe state during and after a path failure. Examples of critical control functions are emergency stop and overtravel stop, power outage and restart.
- Separate or redundant control paths must be provided for critical control functions.
- System control paths may include communication links. Consideration must be given to the implications of unanticipated transmission delays or failures of the link.
- Observe all accident prevention regulations and local safety guidelines.¹
- Each implementation of this equipment must be individually and thoroughly tested for proper operation before being placed into service.

Failure to follow these instructions can result in death, serious injury, or equipment damage.

¹ For additional information, refer to NEMA ICS 1.1 (latest edition), "Safety Guidelines for the Application, Installation, and Maintenance of Solid State Control" and to NEMA ICS 7.1 (latest edition), "Safety Standards for Construction and Guide for Selection, Installation and Operation of Adjustable-Speed Drive Systems" or their equivalent governing your particular location.

WARNING

UNINTENDED EQUIPMENT OPERATION

- Only use software approved by Schneider Electric for use with this equipment.
- Update your application program every time you change the physical hardware configuration.

Failure to follow these instructions can result in death, serious injury, or equipment damage.

Applicable Terminology

The products described in the present document are designed to specific standards and the technical terms, terminology, symbols and the corresponding descriptions in this manual are intended to use the terms or definitions of those pertinent standards.

In the area of functional safety systems, drives and general automation, this may include, but is not limited to, terms such as "safety", "safety function", "safe state", "fault", "fault reset", "malfunction", "failure", "error", "error message", "dangerous", etc.

Among others, these standards include:

Standard	Description
EN 61131-2:2007	Programmable controllers, part 2: Equipment requirements and tests.
ISO 13849-1:2008	Safety of machinery: Safety related parts of control systems. General principles for design.
EN 61496-1:2013	Safety of machinery: Electro-sensitive protective equipment. Part 1: General requirements and tests.
IEC 62061:2005	Safety of machinery. Functional safety of safety-related electrical, electronic, and programmable electronic control systems
ISO 12100:2010	Safety of machinery - General principles for design - Risk assessment and risk reduction
EN 60204-1:2006	Safety of machinery - Electrical equipment of machines - Part 1: General requirements
EN 1088:2008 ISO 14119:2013	Safety of machinery - Interlocking devices associated with guards - Principles for design and selection
ISO 13850:2006	Safety of machinery - Emergency stop - Principles for design
EN/IEC 62061:2005	Safety of machinery - Functional safety of safety-related electrical, electronic, and electronic programmable control systems
IEC 61508-1:2010	Functional safety of electrical/electronic/programmable electronic safety-related systems: General requirements.
IEC 61508-2:2010	Functional safety of electrical/electronic/programmable electronic safety-related systems: Requirements for electrical/electronic/programmable electronic safety-related systems.
IEC 61508-3:2010	Functional safety of electrical/electronic/programmable electronic safety-related systems: Software requirements.
IEC 61784-3:2008	Digital data communication for measurement and control: Functional safety field buses.
2006/42/EC	Machinery Directive
2004/108/EC	Electromagnetic Compatibility Directive
2006/95/EC	Low Voltage Directive

In addition, terms used in the present document may tangentially be used as they are derived from other standards such as:

Standard	Description
IEC 61800 series	Adjustable speed electrical power drive systems
IEC 61158 series	Digital data communications for measurement and control – Fieldbus for use in industrial control systems

Finally, the term "zone of operation" may be used in conjunction with the description of specific hazards, and is defined as it is for a "hazard zone" or "danger zone" in the EC Machinery Directive (EC/2006/42) and ISO 12100-1:2010.

Part I

TM3 Safety General Overview

What Is in This Part?

This part contains the following chapters:

Chapter	Chapter Name	Page
1	TM3 Safety Modules Description	15
2	TM3 Safety Modules Installation	33

Chapter 1

TM3 Safety Modules Description

What Is in This Chapter?

This chapter contains the following sections:

Section	Topic	Page
1.1	Modules and Accessories	16
1.2	Safety Applications Sequential Behavior	23

Section 1.1

Modules and Accessories

What Is in This Section?

This section contains the following topics:

Topic	Page
General Description	17
Physical Description	21

General Description

Introduction

The TM3 safety modules are digital I/O functional safety modules and they can be used to incorporate machine safety into the overall machine control.

The TM3 safety modules are designed to be connected to the M221, M241, M251 logic controllers.

The safety-related functions are managed uniquely by the safety module, independent from the rest of the system. Any communication dependant function is not considered as safety-related.

 WARNING
<p>UNINTENDED EQUIPMENT OPERATION</p> <p>Do not use the data transferred over the TM3 Bus for any functional safety-related task(s).</p> <p>Failure to follow these instructions can result in death, serious injury, or equipment damage.</p>

TM3 Safety Terminology

This table lists the technical terms, acronyms, abbreviations, and their respective description:

Term used	Description
EDM	External Device Monitoring
ESPE	Electro-Sensitive Protective Equipment
K	Refers to: <ul style="list-style-type: none"> ● K1: internal relay ● K2: internal relay ● K3: external contactor ● K4: external contactor
PL	Performance Level
SIL	Safety Integrity Level
S	Refers to safety inputs: <ul style="list-style-type: none"> ● Safety or start inputs: <ul style="list-style-type: none"> ● S11-S12 ● S21-S22 ● S31-S32 ● S41-S42 ● External switches S1, S2, S3, and so on. <p>NOTE: The function depends on the module type.</p>

Term used	Description
Start	Refers to: <ul style="list-style-type: none"> ● Non-monitored: may be manual or automatic mode. Start button must be closed for valid start condition. ● Monitored: start button must be pressed and then released for valid start condition.

Application

Safety systems comprise many components. A single safety component in and of its own does not constitute the safety system. The design of the entire safety system must be considered before attempting to install, operate, or maintain it. The applicable safety standards must be followed when installing and wiring the system components. For more information, refer to the Document Scope (*see page 7*).

Safe State

The TM3 safety modules are operationally defined to be in a safe state when their outputs are off. To exit the safe state condition, a combination of hardware inputs and enabling TM3 Bus communications are required.

The information transacted on the TM3 Bus is not considered part of the safety-related functionality.

 WARNING
--

UNINTENDED EQUIPMENT OPERATION

Do not use the data transferred over the TM3 Bus for any functional safety-related task(s).

Failure to follow these instructions can result in death, serious injury, or equipment damage.

TM3 Safety Modules

This table contains the TM3 safety modules ([see page 61](#)), with the corresponding channel type, nominal voltage/current, and terminal type:

Reference	Function Category	Channels	Channel type	Voltage Current	Terminal type
TM3SAC5R <i>(see page 63)</i>	1 function, up to category 3	1 or 2 ⁽¹⁾	Safety input	24 Vdc 100 mA maximum	3.81 mm (0.15 in.) and 5.08 mm (0.20 in.), removable screw terminal block
		Start ⁽²⁾	Input		
		3 in parallel	Relay outputs Normally open	24 Vdc / 230 Vac 6 A maximum per output	
TM3SAC5RG <i>(see page 63)</i>	1 function, up to category 3	1 or 2 ⁽¹⁾	Safety input	24 Vdc 100 mA maximum	3.81 mm (0.15 in.) and 5.08 mm (0.20 in.), removable spring terminal block
		Start ⁽²⁾	Input		
		3 in parallel	Relay outputs Normally open	24 Vdc / 230 Vac 6 A maximum per output	
TM3SAF5R <i>(see page 73)</i>	1 function, up to category 4	2 ⁽¹⁾	Safety inputs	24 Vdc 100 mA maximum	3.81 mm (0.15 in.) and 5.08 mm (0.20 in.), removable screw terminal block
		Start	Input		
		3 in parallel	Relay outputs Normally open	24 Vdc / 230 Vac 6 A maximum per output	
TM3SAF5RG <i>(see page 73)</i>	1 function, up to category 4	2 ⁽¹⁾	Safety inputs	24 Vdc 100 mA maximum	3.81 mm (0.15 in.) and 5.08 mm (0.20 in.), removable spring terminal block
		Start	Input		
		3 in parallel	Relay outputs Normally open	24 Vdc / 230 Vac 6 A maximum per output	
TM3SAFL5R <i>(see page 83)</i>	2 functions, up to category 3	2 ⁽¹⁾	Safety inputs	24 Vdc 100 mA maximum	3.81 mm (0.15 in.) and 5.08 mm (0.20 in.), removable screw terminal block
		Start	Input		
		3 in parallel	Relay outputs Normally open	24 Vdc / 230 Vac 6 A maximum per output	
TM3SAFL5RG <i>(see page 83)</i>	2 functions, up to category 3	2 ⁽¹⁾	Safety inputs	24 Vdc 100 mA maximum	3.81 mm (0.15 in.) and 5.08 mm (0.20 in.), removable spring terminal block
		Start	Input		
		3 in parallel	Relay outputs Normally open	24 Vdc / 230 Vac 6 A maximum per output	
TM3SAK6R <i>(see page 95)</i>	3 functions, up to category 4	1 or 2 ⁽¹⁾	Safety inputs	24 Vdc 100 mA maximum	3.81 mm (0.15 in.) and 5.08 mm (0.20 in.), removable screw terminal block
		Start	Input		
		3 in parallel	Relay outputs Normally open	24 Vdc / 230 Vac 6 A maximum per output	
⁽¹⁾ Depending on external wiring ⁽²⁾ Non-monitored start					

Reference	Function Category	Channels	Channel type	Voltage Current	Terminal type
TM3SAK6RG (see page 95)	3 functions, up to category 4	1 or 2 ⁽¹⁾	Safety inputs	24 Vdc 100 mA maximum	3.81 mm (0.15 in.) and 5.08 mm (0.20 in.), removable spring terminal block
		Start	Input		
		3 in parallel	Relay outputs Normally open	24 Vdc / 230 Vac 6 A maximum per output	
<p>(1) Depending on external wiring</p> <p>(2) Non-monitored start</p>					

Physical Description

Introduction

This section describes the physical characteristics of the TM3 safety modules.

TM3 Safety Module with Removable Screw or Spring Terminal Block

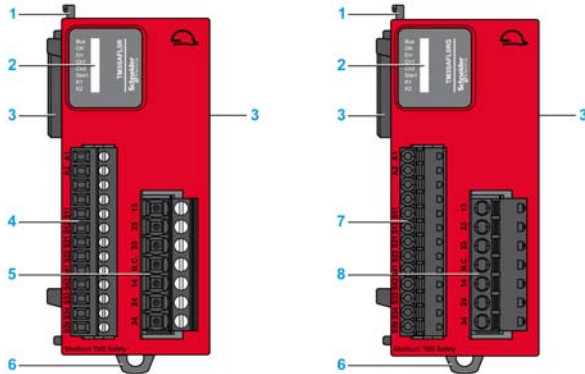

This figure illustrates the main elements of a TM3 safety module with removable screw or spring terminal blocks:



This table describes the main elements of the TM3 safety modules:

Label	Elements	
1	Locking device for attachment to the previous module.	
2	Status LED indicators	
3	Expansion connector for TM3 Bus (one on each side).	
4	Power supply and input removable screw terminal block with a 3.81 mm (0.15 in) pitch.	Rules for removable screw terminal block (see page 55)
5	Relay output removable screw terminal block with a 5.08 mm (0.20 in) pitch.	
6	Clip-on lock for 35 mm (1.38 in.) DIN-rail.	Top hat section rail (DIN rail) (see page 44)
7	Power supply and input removable spring terminal block with a 3.81 mm (0.15 in) pitch.	Rules for removable spring terminal block (see page 56)
8	Relay output removable spring terminal block with a 5.08 mm (0.20 in) pitch.	

This table presents the symbols printed on the product:

Symbol	Reference	Title
	IEC 60417-5032	Alternating current (ac)
	IEC 60417-5031	Direct current (dc)
	ISO 7000-0434A	Caution

Section 1.2

Safety Applications Sequential Behavior

What Is in This Section?

This section contains the following topics:

Topic	Page
One Channel Application	24
Two Channel Application	27
Safety-Mat Application	31

One Channel Application



Performance and Safety Integrity Levels

This table describes the performance and safety integrity levels associated to the 1 channel application:

Application type	Performance Level (PL) and maximum category (IEC/ISO 13849-1)	Maximum Safety Integrity Level (SIL) (IEC/EN 62061)
1 channel application	PL c, category 2	SIL 1

Chronogram Convention

The inputs and outputs behavior description may be based on chronograms. In those chronograms, the following convention on signals status applies:

I/O behavior	Status
	On
	Off
	Optional

Output Activation

Both the safety conditions and the start conditions must be valid before allowing the activation of outputs.

⚠ WARNING
UNINTENDED EQUIPMENT OPERATION
Do not use either the monitored start or the non-monitored start as a safety function. Failure to follow these instructions can result in death, serious injury, or equipment damage.

Non-Monitored Start

This table presents the module types available in a 1 channel application with a non-monitored start:

Reference	Channel 1	Start + EDM 1	EDM 2	Outputs
TM3SAC5R	+24 Vdc - A1	Y1-Y2	-	13-14 23-24 33-34
TM3SAK6R	S11-S12	S33-S39	S41-S42	

This figure represents the output activation management in a 1 channel application with a non-monitored start:

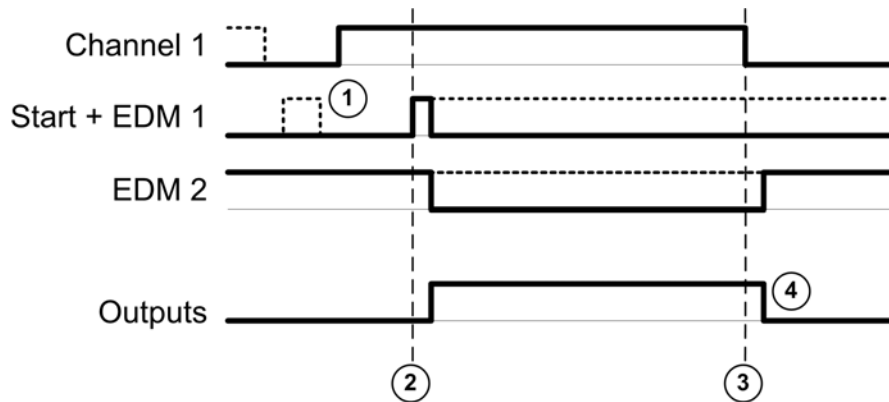

Events description:

1. Non-monitored start condition is available as long as the **start** input is on.
The start condition can be valid before the safety input.
The outputs are on only if start + safety input conditions are valid.
2. Safety inputs + start conditions are valid
3. Safety inputs condition invalid
4. The outputs react to the safety input and start conditions with a delay given by system constraints.

Monitored Start

This table presents the module type available in a 1 channel application with a monitored start:

Reference	Channel 1	Start + EDM 1	EDM 2	Outputs
TM3SAK6R	S11-S12	S33-S34	S41-S42	13-14 23-24 33-34

This figure represents the output activation management in a 1 channel application with a monitored start:

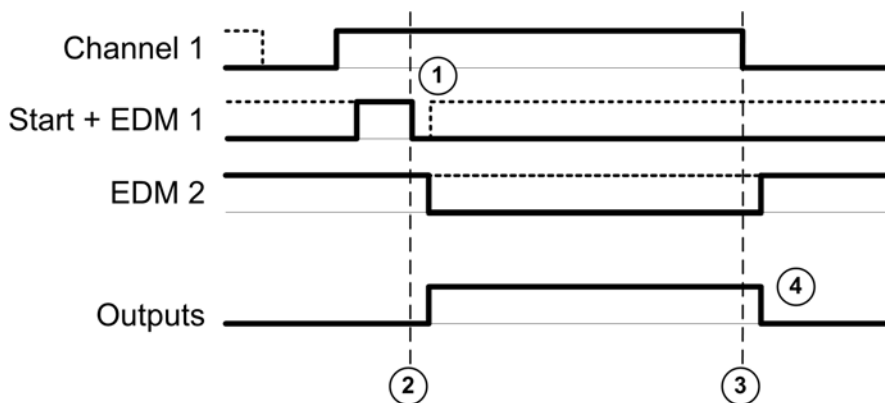

Events description:

1. Monitored start condition is triggered by a falling edge on the **start** input.
2. Safety inputs + start conditions are valid
3. Safety inputs condition invalid
4. The outputs react to the safety input and start conditions with a delay given by system constraints.

Two Channel Application



Performance and Safety Integrity Levels

This table describes the performance and safety integrity levels associated to the 2 channel application:

Application type	Performance Level (PL) and maximum category (IEC/ISO 13849-1)	Maximum Safety Integrity Level (SIL) (IEC/EN 62061)
2 channel application without short-circuit detection	PL d, category 3	SIL 2
2 channel application (2 * PNP sensors) without short-circuit detection	PL d, category 3	SIL 2
2 channel application with short-circuit detection	PL e, category 4	SIL 3
2 channel application (PNP + NPN complementary sensors) with short-circuit detection	PL e, category 4	SIL 3

Chronogram Convention

The inputs and outputs behavior description may be based on chronograms. In those chronograms, the following convention on signals status applies:

I/O behavior	Status
	On
	Off
	Optional

Output Activation

Both the safety conditions and the start conditions must be valid before allowing the activation of outputs.

⚠ WARNING

UNINTENDED EQUIPMENT OPERATION

Do not use either the monitored start or the non-monitored start as a safety function.

Failure to follow these instructions can result in death, serious injury, or equipment damage.

Non-Monitored Start

This table presents the module types available in a 2 channel application with a non-monitored start:

Reference	Channel 1	Channel 2	Start + EDM 1	EDM 2	Outputs
TM3SAC5R	+24 Vdc - A1	A2-GND	Y1-Y2	–	13-14
TM3SAF5R	S11-S12	S21-S22	S33-S39	S41-S42	23-24
TM3SAFL5R					33-34
TM3SAK6R	S21-S22	S31-S32			

This figure represents the output activation management in a 2 channel application with a non-monitored start:

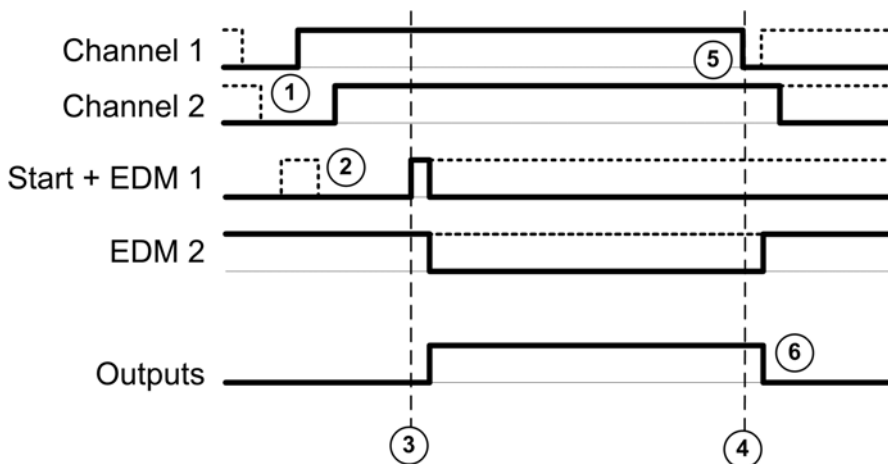

Events description:

1. Both **S2** and **S3** inputs must be set to off before the outputs can be activated. This condition is called interlock. For more information, refer to the TM3 Expansion Modules Programming Guide for your software platform.
2. Non-monitored start condition is available as long as the **start** input is on.
The start condition can be valid before the safety inputs.
The outputs are on only if start + safety inputs conditions are valid.
3. Safety inputs + start conditions are valid
4. Safety inputs condition invalid
5. At least 1 input is off
6. The outputs react to the safety inputs and start conditions with a delay given by system constraints.

Monitored Start

This table presents the module types available in a 2 channel application with a monitored start:

Reference	Channel 1	Channel 2	Start + EDM 1	EDM 2	Outputs
TM3SAF5R	S11-S12	S21-S22	S33-S34	S41-S42	13-14
TM3SAFL5R					23-24
TM3SAK6R	S21-S22	S31-S32			33-34

This figure represents the output activation management in a 2 channel application with a monitored start:

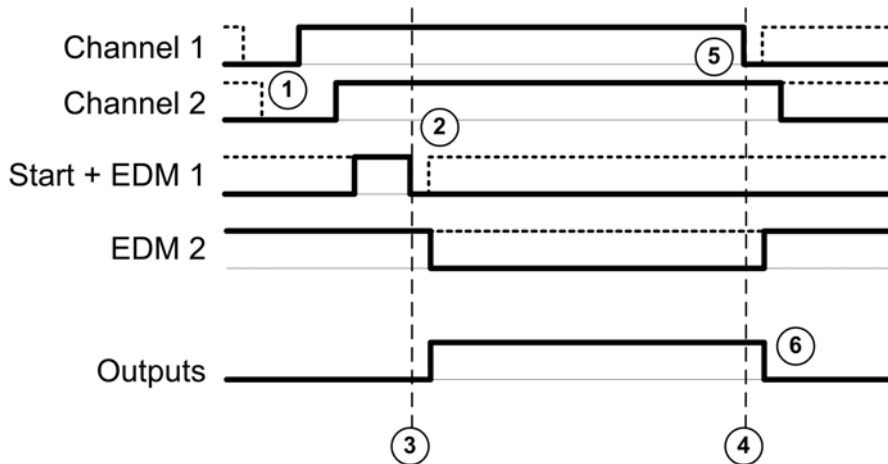

Events description:

1. Both **S2** and **S3** inputs must be set to off before the outputs can be activated. This condition is called interlock. For more information, refer to the TM3 Expansion Modules Programming Guide for your software platform.
2. Monitored start condition is triggered by a falling edge on the **start** input.
3. Safety inputs + start conditions are valid
4. Safety inputs condition invalid
5. At least 1 input is off
6. The outputs react to the safety inputs and start conditions with a delay given by system constraints.

Safety-Mat Application

Performance and Safety Integrity Levels

This table describes the performance and safety integrity levels associated to the safety-mat application:

Application type	Performance Level (PL) and maximum category (IEC/ISO 13849-1)	Maximum Safety Integrity Level (SIL) (IEC/EN 62061)
Safety-mat application (current source)	PL d, category 3	SIL 2

Description

This table presents the module type available in a safety-mat application:

Reference	Channel 1	Channel 2	Start + EDM 1	EDM 2	Outputs
TM3SAK6R	S21-S22	S31-S32	S33-S34	S41-S42	13-14 23-24 33-34

This figure represents the current flow in a safety-mat connected to safety inputs:

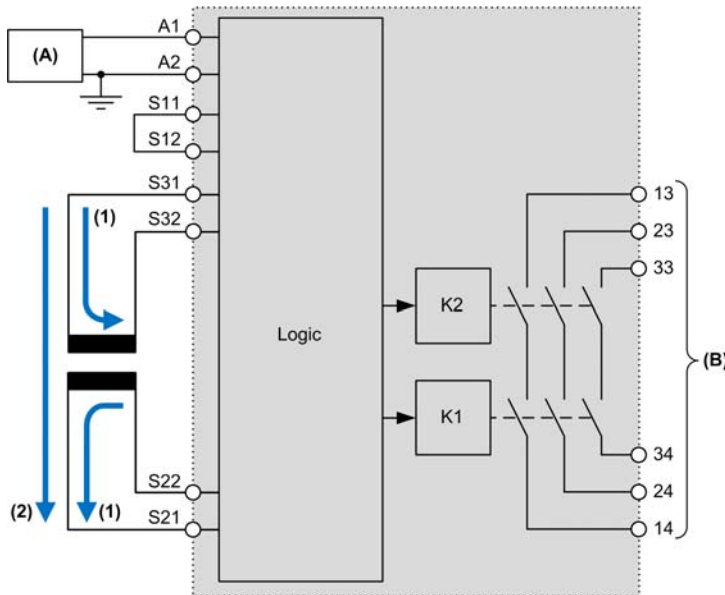

- (A): Current source
- (A1): 24 Vdc
- (A2): GND pin out

(B): Outputs

(1): Current flow when the mat is released, relays K1 and K2 are supplied.

(2): Current flow when the mat is under pressure (mat is stepped on), relays K1 and K2 are not supplied (the mat provides a short circuit path).

Chapter 2

TM3 Safety Modules Installation

What Is in This Chapter?

This chapter contains the following sections:

Section	Topic	Page
2.1	TM3 Safety General Rules for Implementing	34
2.2	TM3 Safety Module Installation	39
2.3	TM3 Safety Electrical Requirements	52

Section 2.1

TM3 Safety General Rules for Implementing

What Is in This Section?

This section contains the following topics:

Topic	Page
Environmental Characteristics	35
Certifications and Standards	38

Environmental Characteristics

Enclosure Requirements

TM3 safety module components are designed as Zone B, Class A industrial equipment according to IEC/CISPR Publication 11. If they are used in environments other than those described in these standards, or in environments that do not meet the specifications in this manual the ability to meet electromagnetic compatibility requirements in the presence of conducted and/or radiated interference may be reduced.

All TM3 safety module components meet European Community (CE) requirements for open equipment as defined by IEC/EN 61131-2. You must install them in an enclosure designed for the specific environmental conditions and to minimize the possibility of unintended contact with hazardous voltages. Use metal enclosures to improve the electromagnetic immunity of your TM3 safety module components. Use enclosures with a keyed locking mechanism to minimize unauthorized access.

Enclosure Recommendation

The TM3 safety module environment must be designed to improve the durability of the equipment.

 WARNING
UNINTENDED EQUIPMENT OPERATION
Install and use the module in a cabinet with an IP54 rating.
Failure to follow these instructions can result in death, serious injury, or equipment damage.

Environmental Characteristics

All the TM3 safety module components are electrically isolated between the internal electronic circuit and the input/output channels.

This equipment meets CE requirements as indicated in the following table. This equipment is intended for use in a Pollution Degree 2 industrial environment.

 WARNING
UNINTENDED EQUIPMENT OPERATION
Do not exceed any of the rated values specified in the environmental and electrical characteristics tables.
Failure to follow these instructions can result in death, serious injury, or equipment damage.

Characteristic		Specification
Standard compliance	IEC/EN 61131-2 IEC/EN 61010-2-201	
Ambient operating temperature	Horizontal installation	-10...55 °C (14...131 °F)
	Vertical installation	-10...35 °C (14...95 °F)
Storage temperature	-40...70 °C (-40...158 °F)	
Relative humidity	Transport and storage	10...95 % (non-condensing)
	Operation	
Pollution degree	IEC/EN 60664-1	2
Degree of protection	IEC/EN 60529	IP20
Overvoltage category	III (4 kV)	
Rated insulation voltage	IEC/EN 60664-1	300 Vac
Corrosion immunity	Atmosphere free from corrosive gases	
Operating altitude	0...2000 m (0...6560 ft)	
Storage altitude	0...3000 m (0...9840 ft)	
Vibration resistance	Panel mounting or mounted on a top hat section rail (DIN rail)	3.5 mm (0.04 in.) fixed amplitude from 5...8.4 Hz 9.8 m/s ² or 32.15 ft/s ² (1 g _n) fixed acceleration from 8.4...150 Hz
Mechanical shock resistance	147 m/s ² or 482.285 ft/s ² (15 g) for 11 ms duration	

Electromagnetic Susceptibility

The TM3 safety module components meet electromagnetic susceptibility specifications as indicated in the table:

Characteristic	Designed to specification	Range	
Electrostatic discharge	IEC/EN 61000-4-2	8 kV (air discharge) 4 kV (contact discharge)	
Radiated electromagnetic field	IEC/EN 61000-4-3	10 V/m (80 MHz...1 GHz) 3 V/m (1.4 GHz...2 GHz) 1 V/m (2...3 GHz)	
Fast transient burst	IEC/EN 61000-4-4	AC/DC Power lines	2 kV
		Relay outputs	2 kV
		24 Vdc I/Os	1 kV
(1) Common mode			
(2) Differential mode			

Characteristic	Designed to specification	Range		
Surge immunity	IEC/EN 61000-4-5 IEC/EN 61131-2	–	CM ⁽¹⁾	DM ⁽²⁾
		DC Power lines	0.5 kV	0.5 kV
		Relay outputs	2 kV	1 kV
		24 Vdc I/Os	0.5 kV	0.5 kV
		Shielded cable (between shield and ground)	1 kV	–
Induced electromagnetic field	IEC/EN 61000-4-6	10 Vrms (0.15...80 MHz)		
Radiated emission	IEC/EN 55011 (IEC/CISPR Publication 11)	Class A, 10 m distance: ● 30...230 MHz: 40 dB μ V/m QP ● 230 MHz...1 GHz: 47 dB μ V/m QP		
(1) Common mode (2) Differential mode				

Certifications and Standards

Introduction

The TM3 safety modules are designed to conform to the main national and international standards concerning electronic industrial control devices:

- IEC/EN 61131-2
- UL 508

The TM3 safety modules have obtained, or are in the process of obtaining, these conformity marks:

- CE
- cULus: pending

The TM3 safety modules comply with the main national and international directives and regulations concerning electronic industrial control devices:

- Europe RoHS:
 - Exemption annex III 7(a)
 - Exemption annex III 7(c)-I
 - Exemption annex III 34

- China RoHS regulations
- REACH v9



Section 2.2

TM3 Safety Module Installation

What Is in This Section?

This section contains the following topics:

Topic	Page
Installation and Maintenance Requirements	40
Installation Guidelines	43
Top Hat Section Rail (DIN rail)	44
Assembling a Module to a Controller or Receiver Module	48
Disassembling a Module from a Controller or Receiver Module	50
Mounting a TM3 Safety Module Directly on a Panel Surface	51

Installation and Maintenance Requirements

Before Starting

Read and understand this chapter before beginning the installation of your system.

The use and application of the information contained herein require expertise in the design and programming of automated control systems. Only you, the user, machine builder or integrator, can be aware of all the conditions and factors present during installation and setup, operation, and maintenance of the machine or process, and can therefore determine the automation and associated equipment and the related safeties and interlocks which can be effectively and properly used. When selecting automation and control equipment, and any other related equipment or software, for a particular application, you must also consider any applicable local, regional or national standards and/or regulations.

Pay particular attention in conforming to any safety information, different electrical requirements, and normative standards that would apply to your machine or process in the use of this equipment.

Disconnecting Power

All options and modules should be assembled and installed before installing the control system on a mounting rail, onto a mounting plate or in a panel. Remove the control system from its mounting rail, mounting plate or panel before disassembling the equipment.



HAZARD OF ELECTRIC SHOCK, EXPLOSION OR ARC FLASH

- Disconnect all power from all equipment including connected devices prior to removing any covers or doors, or installing or removing any accessories, hardware, cables, or wires except under the specific conditions specified in the appropriate hardware guide for this equipment.
- Always use a properly rated voltage sensing device to confirm the power is off where and when indicated.
- Replace and secure all covers, accessories, hardware, cables, and wires and confirm that a proper ground connection exists before applying power to the unit.
- Use only the specified voltage when operating this equipment and any associated products.

Failure to follow these instructions will result in death or serious injury.

Programming Considerations

 WARNING
<p>UNINTENDED EQUIPMENT OPERATION</p> <ul style="list-style-type: none"> • Only use software approved by Schneider Electric for use with this equipment. • Update your application program every time you change the physical hardware configuration. <p>Failure to follow these instructions can result in death, serious injury, or equipment damage.</p>

Operating Environment

This equipment has been designed to operate outside of any hazardous location. Only install this equipment in zones known to be free of a hazardous atmosphere.

 DANGER
<p>POTENTIAL FOR EXPLOSION</p> <p>Install and use this equipment in non-hazardous locations only.</p> <p>Failure to follow these instructions will result in death or serious injury.</p>

 WARNING
<p>UNINTENDED EQUIPMENT OPERATION</p> <p>Install and operate this equipment according to the conditions described in the Environmental Characteristics.</p> <p>Failure to follow these instructions can result in death, serious injury, or equipment damage.</p>

Installation Considerations

WARNING

UNINTENDED EQUIPMENT OPERATION

- Use appropriate safety interlocks where personnel and/or equipment hazards exist.
- Install and operate this equipment in an enclosure appropriately rated for its intended environment.
- Use the sensor and actuator power supplies only for supplying power to the sensors or actuators connected to the module.
- Power line and output circuits must be wired and fused in compliance with local and national regulatory requirements for the rated current and voltage of the particular equipment.
- Do not disassemble, repair, or modify this equipment.
- Do not connect any wiring to reserved, unused connections, or to connections designated as No Connection (N.C.).

Failure to follow these instructions can result in death, serious injury, or equipment damage.

NOTE: JDYX2 or JDYX8 fuse types are UL-recognized and CSA approved.

Installation Guidelines

Introduction

TM3 expansion modules are assembled by connecting them to a logic controller or receiver module.

The logic controller or receiver module and their expansion modules can be installed on a top hat section rail (DIN rail).

Mounting Position and Minimum Clearances

The mounting position and minimum clearances of the expansion modules must conform with the rules defined for the appropriate hardware system. Refer to the *Installation chapter* in the *Controller Hardware* documentation for your specific controller.

WARNING

UNINTENDED EQUIPMENT OPERATION

- Place devices dissipating the most heat at the top of the cabinet and ensure adequate ventilation.
- Avoid placing this equipment next to or above devices that might cause overheating.
- Install the equipment in a location providing the minimum clearances from all adjacent structures and equipment as directed in this document.
- Install all equipment in accordance with the specifications in the related documentation.

Failure to follow these instructions can result in death, serious injury, or equipment damage.

Top Hat Section Rail (DIN rail)

Dimensions of Top Hat Section Rail DIN Rail

You can mount the controller or receiver and its expansions on a 35 mm (1.38 in.) top hat section rail (DIN rail). It can be attached to a smooth mounting surface or suspended from a EIA rack or mounted in a NEMA cabinet.

Symmetric Top Hat Section Rails (DIN Rail)

The following illustration and table show the references of the top hat section rails (DIN rail) for the wall-mounting range:

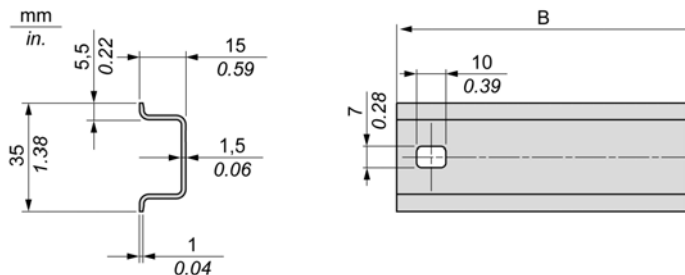

Reference	Type	Rail Length (B)
NSYSR50A	A	450 mm (17.71 in.)
NSYSR60A	A	550 mm (21.65 in.)
NSYSR80A	A	750 mm (29.52 in.)
NSYSR100A	A	950 mm (37.40 in.)

The following illustration and table show the references of the symmetric top hat section rails (DIN rail) for the metal enclosure range:

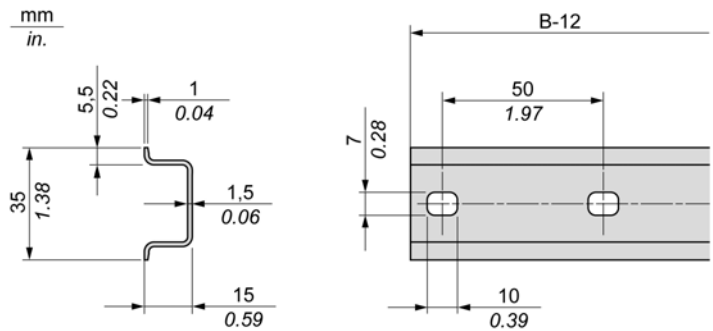

Reference	Type	Rail Length (B-12 mm)
NSYS DR60	A	588 mm (23.15 in.)
NSYS DR80	A	788 mm (31.02 in.)
NSYS DR100	A	988 mm (38.89 in.)
NSYS DR120	A	1188 mm (46.77 in.)

The following illustration and table shows the references of the symmetric top hat section rails (DIN rail) of 2000 mm (78.74 in.):

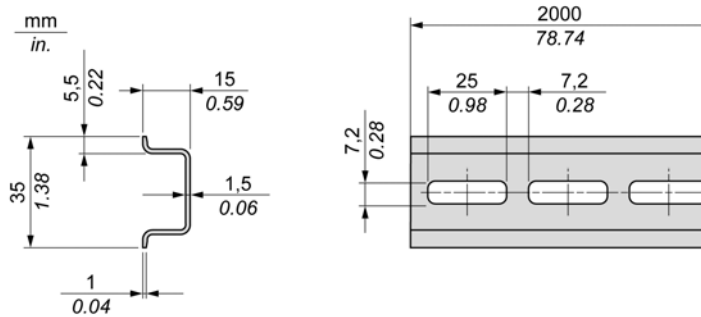

Reference	Type	Rail Length
NSYS DR200 ¹	A	2000 mm (78.74 in.)
NSYS DR200D ²	A	
<p>1 Unperforated galvanized steel</p> <p>2 Perforated galvanized steel</p>		

Double-Profile Top Hat Section Rails (DIN rail)

The following illustration and table show the references of the double-profile top hat section rails (DIN rails) for the wall-mounting range:

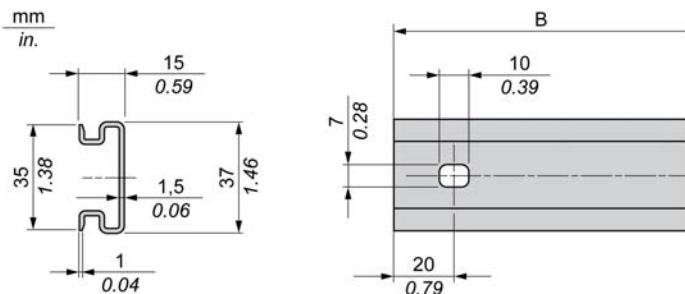

Reference	Type	Rail Length (B)
NSYDPR25	W	250 mm (9.84 in.)
NSYDPR35	W	350 mm (13.77 in.)
NSYDPR45	W	450 mm (17.71 in.)
NSYDPR55	W	550 mm (21.65 in.)
NSYDPR65	W	650 mm (25.60 in.)
NSYDPR75	W	750 mm (29.52 in.)

The following illustration and table show the references of the double-profile top hat section rails (DIN rail) for the floor-standing range:

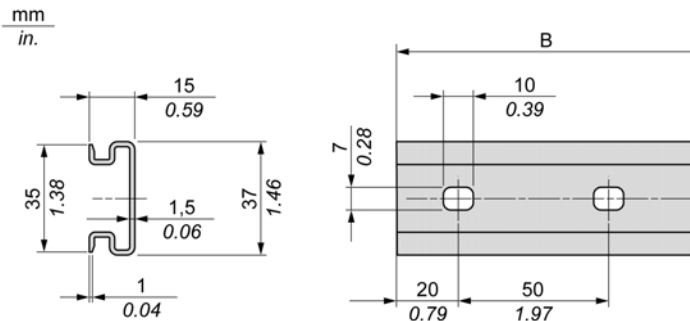

Reference	Type	Rail Length (B)
NSYDPR60	F	588 mm (23.15 in.)
NSYDPR80	F	788 mm (31.02 in.)

Reference	Type	Rail Length (B)
NSYDPR100	F	988 mm (38.89 in.)
NSYDPR120	F	1188 mm (46.77 in.)

Assembling a Module to a Controller or Receiver Module

Introduction

This section describes how to assemble an expansion module to a controller, Receiver module or other modules.

DANGER

HAZARD OF ELECTRIC SHOCK, EXPLOSION OR ARC FLASH

- Disconnect all power from all equipment including connected devices prior to removing any covers or doors, or installing or removing any accessories, hardware, cables, or wires except under the specific conditions specified in the appropriate hardware guide for this equipment.
- Always use a properly rated voltage sensing device to confirm the power is off where and when indicated.
- Replace and secure all covers, accessories, hardware, cables, and wires and confirm that a proper ground connection exists before applying power to the unit.
- Use only the specified voltage when operating this equipment and any associated products.

Failure to follow these instructions will result in death or serious injury.

After connecting new modules to the controller, either directly or through a transmitter/receiver, update and reupload your application program before placing the system back in service. If you do not revise your application program to reflect the addition of new modules, I/O located on the expansion bus may no longer operate normally.

WARNING

UNINTENDED EQUIPMENT OPERATION

- Only use software approved by Schneider Electric for use with this equipment.
- Update your application program every time you change the physical hardware configuration.

Failure to follow these instructions can result in death, serious injury, or equipment damage.

Assembling a Module to a Controller or Receiver Module

The following procedure shows how to assemble a controller or receiver module and a module together.

Step	Action
1	Remove all power and dismount any existing controller I/O assembly from its DIN mounting.
2	Remove the expansion connector sticker from the controller or the outermost installed expansion module.
3	Verify that the locking device (<i>see Modicon TM3, Transmitter and Receiver Modules, Hardware Guide</i>) on the new module is in the upper position.
4	Align the internal bus connector on the left side of the module with the internal bus connector on the right side of the controller, Receiver module or expansion module.
5	Press the new module towards the controller, Receiver module or expansion module until it is securely in place.
6	Push down the locking device (<i>see Modicon TM3, Transmitter and Receiver Modules, Hardware Guide</i>) on the top of the new module to lock it to the controller, Receiver module or previously installed expansion module.

Disassembling a Module from a Controller or Receiver Module

Introduction

This section describes how to disassemble a module from a controller or receiver module.

DANGER

HAZARD OF ELECTRIC SHOCK, EXPLOSION OR ARC FLASH

- Disconnect all power from all equipment including connected devices prior to removing any covers or doors, or installing or removing any accessories, hardware, cables, or wires except under the specific conditions specified in the appropriate hardware guide for this equipment.
- Always use a properly rated voltage sensing device to confirm the power is off where and when indicated.
- Replace and secure all covers, accessories, hardware, cables, and wires and confirm that a proper ground connection exists before applying power to the unit.
- Use only the specified voltage when operating this equipment and any associated products.

Failure to follow these instructions will result in death or serious injury.

Disassembling a Module from a Controller or Receiver Module

The following procedure describes how to disassemble a module from a controller or receiver module.

Step	Action
1	Remove all power from the control system.
2	Dismount the assembled controller and modules from the mounting rail.
3	Push up the locking device (<i>see Modicon TM3, Digital I/O Modules, Hardware Guide</i>) from the bottom of the module to disengage it from the controller or receiver module.
4	Pull apart module from the controller or receiver module.

Mounting a TM3 Safety Module Directly on a Panel Surface

Overview

This section shows how to install a TM3 safety module using the panel mounting kit and the module mounting holes layout.

Installing the Panel Mount Kit

The following procedure shows how to install a mounting strip:

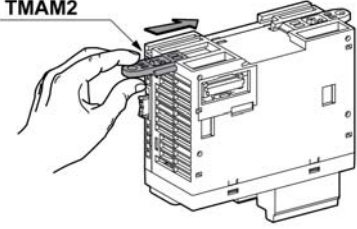
Step	Action
1	<p>Insert the mounting strip TMAM2 into the slot at the top of the TM3 safety module.</p>  <p>The diagram shows a hand holding a small, dark-colored mounting strip labeled 'TMAM2' and inserting it into a slot at the top of a white TM3 safety module. An arrow points to the slot, and another arrow points to the strip being inserted.</p>

Mounting Hole Layout

The following diagram shows the mounting holes for a TM3 safety module:

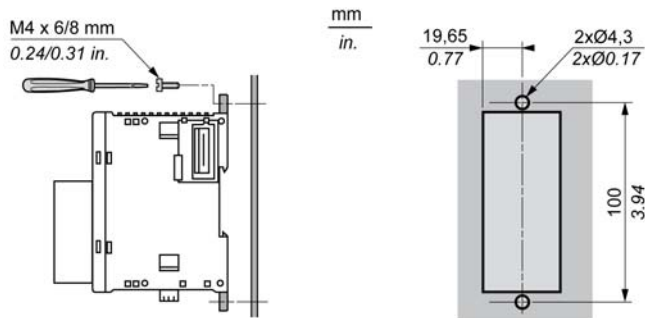

Section 2.3

TM3 Safety Electrical Requirements

What Is in This Section?

This section contains the following topics:

Topic	Page
Wiring Best Practices	53
DC Power Supply Characteristics	59

Wiring Best Practices

Overview

This section describes the wiring guidelines and associated best practices to be respected when using TM3 safety modules.

DANGER

HAZARD OF ELECTRIC SHOCK, EXPLOSION OR ARC FLASH

- Disconnect all power from all equipment including connected devices prior to removing any covers or doors, or installing or removing any accessories, hardware, cables, or wires except under the specific conditions specified in the appropriate hardware guide for this equipment.
- Always use a properly rated voltage sensing device to confirm the power is off where and when indicated.
- Replace and secure all covers, accessories, hardware, cables, and wires and confirm that a proper ground connection exists before applying power to the unit.
- Use only the specified voltage when operating this equipment and any associated products.

Failure to follow these instructions will result in death or serious injury.

WARNING

LOSS OF CONTROL

- The designer of any control scheme must consider the potential failure modes of control paths and, for certain critical control functions, provide a means to achieve a safe state during and after a path failure. Examples of critical control functions are emergency stop and overtravel stop, power outage and restart.
- Separate or redundant control paths must be provided for critical control functions.
- System control paths may include communication links. Consideration must be given to the implications of unanticipated transmission delays or failures of the link.
- Observe all accident prevention regulations and local safety guidelines.¹
- Each implementation of this equipment must be individually and thoroughly tested for proper operation before being placed into service.

Failure to follow these instructions can result in death, serious injury, or equipment damage.

¹ For additional information, refer to NEMA ICS 1.1 (latest edition), "Safety Guidelines for the Application, Installation, and Maintenance of Solid State Control" and to NEMA ICS 7.1 (latest edition), "Safety Standards for Construction and Guide for Selection, Installation and Operation of Adjustable-Speed Drive Systems" or their equivalent governing your particular location.

Functional Ground (FE) on a Top Hat Section Rail (DIN Rail)

The top hat section rail (DIN Rail) for your system is common with the functional ground (FE) plane and must be mounted on a conductive backplane.

WARNING

UNINTENDED EQUIPMENT OPERATION

Connect the DIN rail to the functional ground (FE) of your installation.

Failure to follow these instructions can result in death, serious injury, or equipment damage.

Wiring Guidelines

The following rules must be applied when wiring a TM3 safety module:

- I/O and communication wiring must be kept separate from the power wiring. Route these 2 types of wiring in separate cable ducting.
- Verify that the operating conditions and environment are within the specification values.
- Use proper wire sizes to meet voltage and current requirements.
- Use copper conductors.
- Use twisted pair, shielded cables for I/O.
- Use twisted pair, shielded cables for networks, and fieldbus.

WARNING

UNINTENDED EQUIPMENT OPERATION









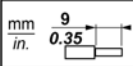

- Use shielded cables for all fast I/O, analog I/O, and communication signals.
- Ground cable shields for all fast I/O, analog I/O, and communication signals at a single point¹.
- Route communications and I/O cables separately from power cables.



Failure to follow these instructions can result in death, serious injury, or equipment damage.

¹Multipoint grounding is permissible if connections are made to an equipotential ground plane dimensioned to help avoid cable shield damage in the event of power system short-circuit currents.









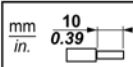

Rules for Removable Screw Terminal Block



The following tables show the cable types and wire sizes for a **3.81 mm (0.15 in.) pitch** removable screw terminal block (I/Os and power supply):

									
mm ²	0,14...1,5	0,14...1,5	0,25...0,5	0,25...1,5	2 x 0,14...0,5	2 x 0,14...0,75	2 x 0,25...0,34	2 x 0,5	
AWG	26...16	26...16	24...20	24...16	2 x 26...20	2 x 26...18	2 x 24...22	2 x 20	

		N•m	0,22...0,25
Ø 2,5 mm (0.1 in.)		lb-in	2.0...2.2

The following tables show the cable types and wire sizes for a **5.08 mm (0.20 in.) pitch** removable screw terminal block (outputs):

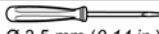
									
mm ²	0,2...2,5	0,2...2,5	0,25...2,5	0,25...2,5	2 x 0,2...1,5	2 x 0,2...1,5	2 x 0,25...1,0	2 x 0,5...1,5	
AWG	24...12	24...12	24...12	24...12	2 x 24...16	2 x 24...16	2 x 24...18	2 x 20...16	

		N•m	0,5...0,6
Ø 3,5 mm (0.14 in.)		lb-in	4.4...5.3

The use of copper conductors is required.

⚠ DANGER





FIRE HAZARD

- Use only the recommended wire sizes for the current capacity of the I/O channels and power supplies.
- For relay output (2 A) wiring, use conductors of at least 0.5 mm² (AWG 20) with a temperature rating of at least 90 °C (194 °F).
- For common conductors of relay output wiring (7 A), or relay output wiring greater than 2 A, use conductors of at least 1.0 mm² (AWG 16) with a temperature rating of at least 90 °C (194 °F).



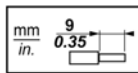



Failure to follow these instructions will result in death or serious injury.

Rules for Removable Spring Terminal Block

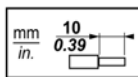
The following tables show the cable types and wire sizes for a **3.81 mm (0.15 in.) pitch** removable spring terminal block (I/Os and power supply):

				
mm ²	0.14...1.5	0.14...1.5	0.25...0.5	0.25...1.5
AWG	26...16	26...16	24...20	24...16

The following tables show the cable types and wire sizes for a **5.08 mm (0.20 in.) pitch** removable spring terminal block (outputs):

					
mm ²	0.2...2.5	0.2...2.5	0.25...2.5	0.25...2.5	2 x 0.5...1
AWG	24...12	24...12	24...12	24...12	2 x 20...18

The use of copper conductors is required.

⚠ DANGER

FIRE HAZARD

- Use only the recommended wire sizes for the current capacity of the I/O channels and power supplies.
- For relay output (2 A) wiring, use conductors of at least 0.5 mm² (AWG 20) with a temperature rating of at least 90 °C (194 °F).
- For common conductors of relay output wiring (7 A), or relay output wiring greater than 2 A, use conductors of at least 1.0 mm² (AWG 16) with a temperature rating of at least 90 °C (194 °F).

Failure to follow these instructions will result in death or serious injury.

The spring clamp connectors of the terminal block are designed for only one wire or one cable end. Two wires to the same connector must be installed with a double wire cable end to help prevent loosening.

⚡ ⚠ DANGER

LOOSE WIRING CAUSES ELECTRIC SHOCK

Do not insert more than one wire per connector of the terminal block without a double wire cable end.

Failure to follow these instructions will result in death or serious injury.

Protecting Outputs from Inductive Load Damage

Depending on the load, a protection circuit may be needed for the outputs on the controllers and certain modules. Inductive loads using DC voltages may create voltage reflections resulting in overshoot that will damage or shorten the life of output devices.

⚠ CAUTION

OUTPUT CIRCUIT DAMAGE DUE TO INDUCTIVE LOADS

Use an appropriate external protective circuit or device to reduce the risk of inductive direct current load damage.

Failure to follow these instructions can result in injury or equipment damage.

If your controller or module contains relay outputs, these types of outputs can support up to 240 Vac. Inductive damage to these types of outputs can result in welded contacts and loss of control. Each inductive load must include a protection device such as a peak limiter, RC circuit or flyback diode. Capacitive loads are not supported by these relays.

⚠ WARNING

RELAY OUTPUTS WELDED CLOSED

- Always protect relay outputs from inductive alternating current load damage using an appropriate external protective circuit or device.
- Do not connect relay outputs to capacitive loads.

Failure to follow these instructions can result in death, serious injury, or equipment damage.

Protective circuit A: this protection circuit can be used for both AC and DC load power circuits.

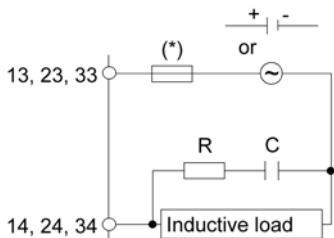

(*) Fuses. Refer to electrical characteristics for fuse values.

- C represents a value from 0.1 to 1 μF .
- R represents a resistor of approximately the same resistance value as the load.

Protective circuit B: this protection circuit can be used for DC load power circuits.

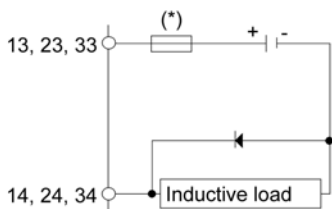

(*) Fuses. Refer to electrical characteristics for fuse values.

Use a diode with the following ratings:

- Reverse withstand voltage: power voltage of the load circuit x 10.
- Forward current: more than the load current.

Protective circuit C: this protection circuit can be used for both AC and DC load power circuits.

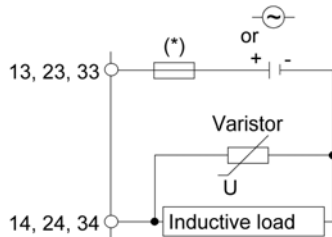

(*) Fuses. Refer to electrical characteristics for fuse values.

- In applications where the inductive load is switched on and off frequently and/or rapidly, ensure that the continuous energy rating (J) of the varistor exceeds the peak load energy by 20 % or more.

DC Power Supply Characteristics

Overview

This section provides the characteristics of the DC power supply.

Power Supply Voltage Range

If the specified voltage range is not maintained, outputs may not switch as expected. Use appropriate safety interlocks and voltage monitoring circuits.

DANGER

FIRE HAZARD

- Use only the recommended wire sizes for the current capacity of the I/O channels and power supplies.
- For relay output (2 A) wiring, use conductors of at least 0.5 mm² (AWG 20) with a temperature rating of at least 90 °C (194 °F).
- For common conductors of relay output wiring (7 A), or relay output wiring greater than 2 A, use conductors of at least 1.0 mm² (AWG 16) with a temperature rating of at least 90 °C (194 °F).

Failure to follow these instructions will result in death or serious injury.

WARNING

UNINTENDED EQUIPMENT OPERATION

Do not exceed any of the rated values specified in the environmental and electrical characteristics tables.

Failure to follow these instructions can result in death, serious injury, or equipment damage.

DC Power Supply Characteristics

The 24 Vdc power supply must meet the regulations for extra low voltages with safe separation:

- Protective Extra Low Voltage (PELV) according to IEC/EN 60950-1 or
- Safety Extra Low Voltage (SELV) according to IEC/EN 60204-1, EN 50178/IEC 62103, and IEC 60364-4-4.

These power supplies are isolated between the electrical input and output circuits of the power supply.

WARNING

POTENTIAL OF OVERHEATING AND FIRE

- Do not connect the equipment directly to line voltage.
- Use only isolating PELV or SELV power supplies to supply power to the equipment.

Failure to follow these instructions can result in death, serious injury, or equipment damage.

Part II

TM3 Safety Modules

What Is in This Part?

This part contains the following chapters:

Chapter	Chapter Name	Page
3	TM3SAC5R / TM3SAC5RG Module, 1 Function Cat3	63
4	TM3SAF5R / TM3SAF5RG Module, 1 Function Cat4	73
5	TM3SAFL5R / TM3SAFL5RG Module, 2 Functions Cat3	83
6	TM3SAK6R / TM3SAK6RG Module, 3 Functions Cat4	95

Chapter 3

TM3SAC5R / TM3SAC5RG Module, 1 Function Cat3

Overview

This chapter describes the TM3SAC5R• module, its characteristics, and its connection.

What Is in This Chapter?

This chapter contains the following topics:

Topic	Page
TM3SAC5R / TM3SAC5RG Presentation	64
TM3SAC5R / TM3SAC5RG Characteristics	66
TM3SAC5R / TM3SAC5RG Wiring Diagram	69

TM3SAC5R / TM3SAC5RG Presentation

Overview

The main characteristics of the TM3SAC5R (screw) and TM3SAC5RG (spring) modules are:

- 1 channel or 2 channels
- 24 Vdc
- Removable screw or spring terminal

Main Characteristics

This table describes the main characteristics of the TM3SAC5R• module:

Characteristic		Value
Number of safety input channels		2
Start mode		Non-monitored
Supply voltage		24 Vdc -15...+20 %
Number of outputs		3 parallel relay outputs, stop category 0
Rated output voltage		24 Vdc / 230 Vac 6 A maximum per output path
Connection type	TM3SAC5R	Removable screw terminal block
	TM3SAC5RG	Removable spring terminal block
Weight		190 g (6.70 oz)

Associated Applications

This table defines the type and example of applications that can be associated to the TM3SAC5R• module:

Application type	Application example
1 channel application (see page 24)	<ul style="list-style-type: none"> ● Monitoring 1 channel emergency stop circuits ● Monitoring 1 channel limit switches on protective guards
2 channel application without short-circuit detection (see page 27)	<ul style="list-style-type: none"> ● Monitoring 2 channel emergency stop circuits without short-circuit detection ● Monitoring 2 channel limit switches on protective guards without short-circuit detection

Status LED

This figure shows the status LEDs:



This table provides the TM3SAC5R• module status LED indicators description:

LED	Color	Status	Description
Bus	Green	Flashing	The module is receiving the 5 Vdc power supply from the TM3 Bus and the TM3 Bus is functioning.
A1/A2	Green	On	+24 Vdc power supply provided to the module is in the voltage tolerance.
		Flashing	TM3 Bus time-out: the safety operation is maintained.
Err	Red	On	+24 Vdc power supply provided to the module is out of the voltage tolerance.
		Flashing	TM3 Bus time-out: the safety output is deactivated (off).
Start	Green	On	Start condition valid (The circuit between Y1-Y2 is closed).
K1	Green	On	K1 relay energized (closed)
		Flashing	Waiting for start condition
K2	Green	On	K2 relay energized (closed)
		Flashing	Waiting for start condition

TM3SAC5R / TM3SAC5RG Characteristics

Introduction

This section provides a description of the characteristics of TM3SAC5R / TM3SAC5RG safety modules.

See also Environmental Characteristics (*see page 35*).

⚠ WARNING

UNINTENDED EQUIPMENT OPERATION

Do not exceed any of the rated values specified in the environmental and electrical characteristics tables.

Failure to follow these instructions can result in death, serious injury, or equipment damage.

Dimensions

This diagram shows the external dimensions of the TM3SAC5R / TM3SAC5RG safety modules:

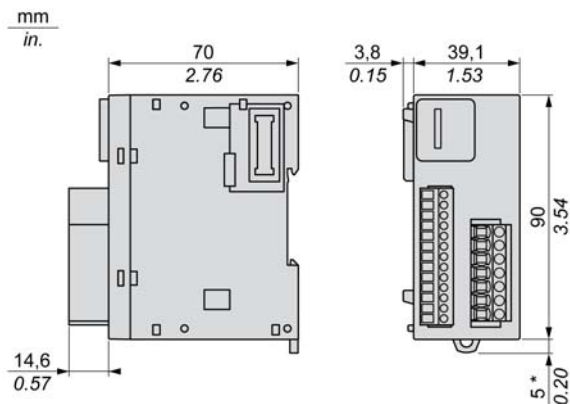

* 8.5 mm (0.33 in.) when the clamp is pulled out.

Safety-related

The TM3SAC5R• module is a safety module for monitoring emergency stop and limit switches on protective guards according to ISO/EN 13849, IEC/EN 62061, IEC/EN 61058. The module has these safety-related characteristics:

Characteristic	Designed to specification	Value
Safety integrity level (SIL)	IEC/EN 61508-1:2010	2
Safety integrity level claim limit (SILCL)	IEC/EN 62061:2005	2
Safe failure fraction (SFF)	IEC/EN 61508-1:2010	95 %
Hardware fault tolerance (HFT)	IEC/EN 61508-1:2010	1
Type	IEC/EN 61508-1:2010	A
Mode of operation	IEC/EN 61508-1:2010	High demand mode
Probability of dangerous failures per hour (PFHd)	IEC/EN 61508-1:2010	$30 \cdot 10^{-9} / \text{h}^{(1)}$
		$5 \cdot 10^{-9} / \text{h}^{(2)}$
Mean time to dangerous failure (MTTFd)	ISO/EN 13849-1:2008	85 years ⁽¹⁾
		500 years ⁽²⁾
Performance level (PL) category (cat.)	ISO/EN 13849-1:2008	PL d. cat. 3
Diagnostic coverage (DC)	ISO/EN 13849-1:2008	95 %
Lifetime	–	20 years
Response time	–	20 ms
Proof test interval (PTI)	–	None
Stop category	IEC/EN 60204-1	0
Start	–	Manual or automatic
Paths	–	<ul style="list-style-type: none"> • 3 enabling paths • 1 signaling path
Feedback	–	Feedback loop to monitor external contactors.
Safe state	–	The TM3 safety modules are in safe state when their outputs are off (internal relays are not energized; output path is open).
<p>NOTE: These modules contain electromechanical relays, so actual MTTFd and PFHd values vary depending on the application load and duty cycle.</p> <p>(1) 60 operation cycles per hour at DC-13 24 Vdc 1 A (2) 1 operation cycle per hour at DC-13 24 Vdc 4 A</p>		

Power Supply

This table describes the power supply characteristics of the TM3 safety module:

Characteristic		Value
Supply voltage	IEC 60038	24 Vdc -15...+20 %
External fuse protection (maximum)		4 A slow blow (class gG)
Power consumption	24 Vdc supply voltage	3.6 W
	TM3 Bus (5 Vdc)	0.2 W

Control Circuit

This table describes the control circuit characteristics of the TM3 safety module:

Characteristic		Value
Input voltage (high)	Minimum	20.4 Vdc
	Nominal	24 Vdc
	Maximum	28.8 Vdc
Input voltage (low)	Nominal	0 Vdc
Input current (high)	Nominal	70 mA
	Maximum	150 mA
Input current (low)	Nominal	0 mA
Response time		≤ 20 ms
Delay	On	≤ 100 ms
	Restart	≤ 300 ms

Output Circuit

This table describes the output circuit characteristics of the TM3 safety module:

Characteristic		Value
Maximum switching current of each output	AC-15: 230 Vac	5 A
	DC-13: 24 Vdc	4 A
Minimum switching voltage and current (new contact never used with higher loads)		17 V, 10 mA
Maximum current	Per output path	6 A
	Sum of current in all output paths	≤ 18 A
External fuse protection (maximum)	Slow blow (class gG) fuse	4 A
	Fast blow fuse	6 A
Maximum switching operations		10 * 10 ⁶

TM3SAC5R / TM3SAC5RG Wiring Diagram

Introduction

These safety modules have a built-in removable screw or spring terminal block for the connection of inputs and outputs.

Wiring Rules

See Wiring Best Practices ([see page 53](#)).

The 24 Vdc power supply must be rated Protective Extra Low Voltage (PELV) or Safety Extra Low Voltage (SELV) and fulfill the IEC/EN 60204-1 requirements. These power supplies are isolated between the electrical input and output circuits of the power supply.

WARNING

POTENTIAL OF OVERHEATING AND FIRE

- Do not connect the equipment directly to line voltage.
- Use only isolating PELV or SELV power supplies to supply power to the equipment.

Failure to follow these instructions can result in death, serious injury, or equipment damage.

WARNING

LOSS OF CONTROL

Place a properly rated fuse on the primary input power line and on the outputs, as described in the related documentation.

Failure to follow these instructions can result in death, serious injury, or equipment damage.

Emergency Stop Wiring Diagram

Both the safety conditions and the start conditions must be valid before allowing the activation of outputs.

 **WARNING**

UNINTENDED EQUIPMENT OPERATION

Do not use either the monitored start or the non-monitored start as a safety function.

Failure to follow these instructions can result in death, serious injury, or equipment damage.

This figure shows an example of emergency stop wiring to a TM3SAC5R• module:

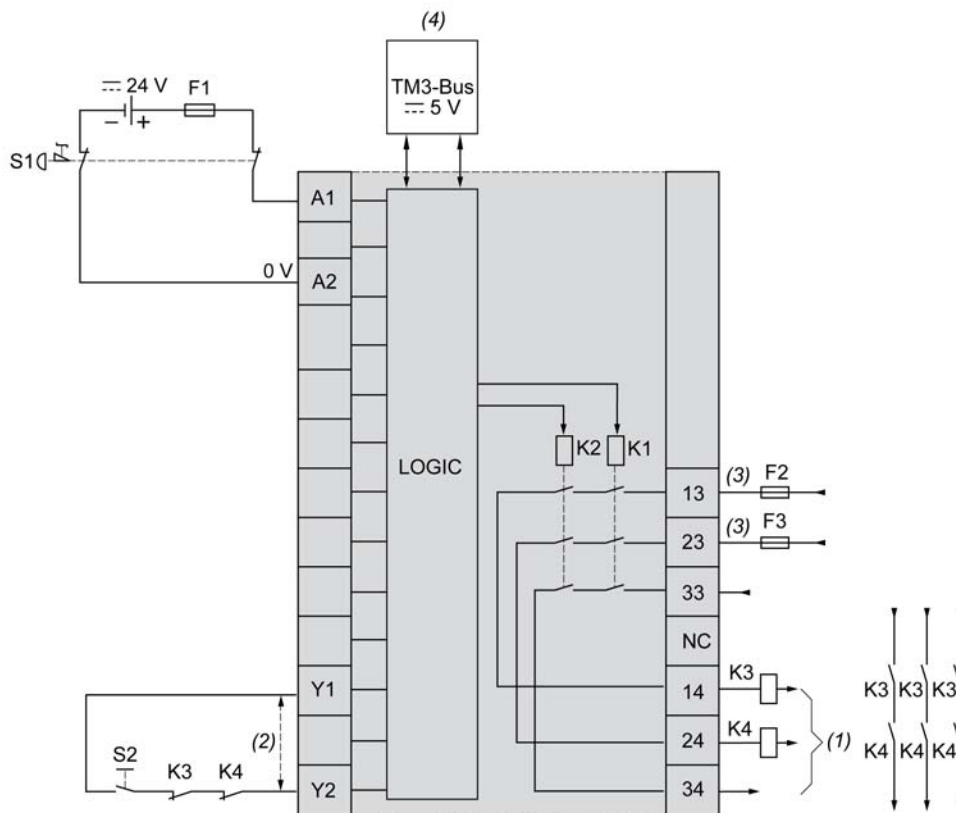

S1: Emergency stop switch

S2: Start switch

- (1): Safety outputs
- (2): For automatic start, directly connect [Y1] and [Y2] terminals. For more information, refer to the TM3 Expansion Modules Programming Guide for your software platform.
- (3): Fuses. Refer to electrical characteristics for fuse values.
- (4): Non-safety related TM3 Bus communication with logic controller

 **WARNING****UNINTENDED EQUIPMENT OPERATION**

Do not use the data transferred over the TM3 Bus for any functional safety-related task(s).

Failure to follow these instructions can result in death, serious injury, or equipment damage.

 **WARNING****UNINTENDED EQUIPMENT OPERATION**

Do not connect wires to unused terminals and/or terminals indicated as “No Connection (N.C.)”.

Failure to follow these instructions can result in death, serious injury, or equipment damage.

Chapter 4

TM3SAF5R / TM3SAF5RG Module, 1 Function Cat4

Overview

This chapter describes the TM3SAF5R• module, its characteristics, and its connection.

What Is in This Chapter?

This chapter contains the following topics:

Topic	Page
TM3SAF5R / TM3SAF5RG Presentation	74
TM3SAF5R / TM3SAF5RG Characteristics	76
TM3SAF5R / TM3SAF5RG Wiring Diagram	79

TM3SAF5R / TM3SAF5RG Presentation

Overview

The main characteristics of the TM3SAF5R (screw) and TM3SAF5RG (spring) modules are:

- 2 channels
- 24 Vdc
- Removable screw or spring terminal

Main Characteristics

This table describes the main characteristics of the TM3SAF5R• module:

Characteristic		Value
Number of safety input channels		2
Start mode		Monitored / Non-monitored start
Supply voltage		24 Vdc -15...+20 %
Number of outputs		3 parallel relay outputs, stop category 0
Rated output voltage		24 Vdc / 230 Vac 6 A maximum per output path
Connection type	TM3SAF5R	Removable screw terminal block
	TM3SAF5RG	Removable spring terminal block
Weight		190 g (6.70 oz)

Associated Applications

This table defines the type and example of applications that can be associated to the TM3SAF5R• module:

Application type	Application example
2 channel application (see page 27) with short-circuit detection	<ul style="list-style-type: none"> • Monitoring 2 channel emergency stop circuits with short-circuits detection • Monitoring 2 channel limit switches on protective guards with short-circuit detection

Status LED

This figure shows the status LEDs:

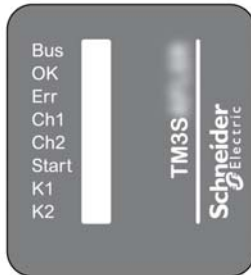

This table provides the TM3SAF5R• module status LED indicators description:

LED	Color	Status	Description
Bus	Green	Flashing	The module is receiving the 5 Vdc power supply from the TM3 Bus and the TM3 Bus is functioning.
OK	Green	On	+24 Vdc power supply provided to the module is in the voltage tolerance.
		Flashing	TM3 Bus time-out: the functional safety operation is maintained.
Err	Red	On	+24 Vdc power supply provided to the module is out of the voltage tolerance.
		Flashing	TM3 Bus time-out: the safety output is deactivated (off).
Ch1	Green	On	Channel 1 is active: The circuit between S21-S22 is closed.
Ch2	Green	On	Channel 2 is active: The circuit between S11-S12 is closed. See note below.
Start	Green	On	Start condition valid: inputs S11-S12, S21-S22, and S41-S42 (EDM 2) closed, and S34 or S39 connected to S33. See note below.
K1	Green	On	K1 relay energized (closed)
		Flashing	Waiting for start condition
K2	Green	On	K2 relay energized (closed)
		Flashing	Waiting for start condition

NOTE: While waiting for Start there is no indication of **Ch2** if S41-S42 (EDM 2) is open (by feedback of external device (NC contact)).

TM3SAF5R / TM3SAF5RG Characteristics

Introduction

This section provides a description of the characteristics of TM3SAF5R / TM3SAF5RG safety modules.

See also Environmental Characteristics (*see page 35*).

⚠ WARNING

UNINTENDED EQUIPMENT OPERATION

Do not exceed any of the rated values specified in the environmental and electrical characteristics tables.

Failure to follow these instructions can result in death, serious injury, or equipment damage.

Dimensions

This diagram shows the external dimensions of the TM3SAF5R / TM3SAF5RG safety modules:

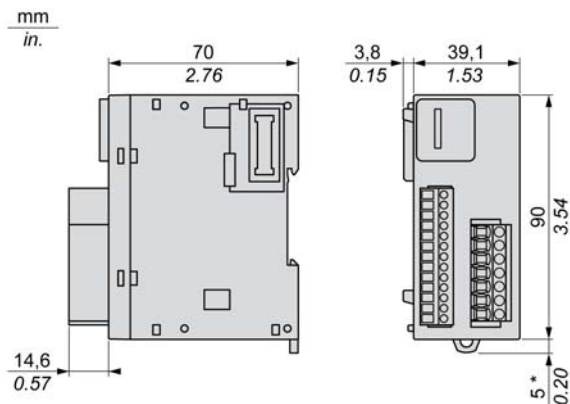

* 8.5 mm (0.33 in.) when the clamp is pulled out.

Safety-related

The TM3SAF5R• module is a safety module for monitoring emergency stop and limit switches on protective guards according to ISO/EN 13849, IEC/EN 62061, IEC/EN 61058. The module has these safety-related characteristics:

Characteristic	Designed to specification	Value
Safety integrity level (SIL)	IEC/EN 61508-1:2010	3
Safety integrity level claim limit (SILCL)	IEC/EN 62061:2005	3
Safe failure fraction (SFF)	IEC/EN 61508-1:2010	95 %
Hardware fault tolerance (HFT)	IEC/EN 61508-1:2010	1
Type	IEC/EN 61508-1:2010	A
Mode of operation	IEC/EN 61508-1:2010	High demand mode
Probability of dangerous failures per hour (PFHd)	IEC/EN 61508-1:2010	$30 \cdot 10^{-9} / \text{h}^{(1)}$
		$5 \cdot 10^{-9} / \text{h}^{(2)}$
Mean time to dangerous failure (MTTFd)	ISO/EN 13849-1:2008	85 years ⁽¹⁾
		500 years ⁽²⁾
Performance level (PL) category (cat.)	ISO/EN 13849-1:2008	PL e. cat. 4
Diagnostic coverage (DC)	ISO/EN 13849-1:2008	95 %
Lifetime	–	20 years
Response time	–	20 ms
Proof test interval (PTI)	–	None
Stop category	IEC/EN 60204-1	0
Start	–	Manual or automatic
Paths	–	<ul style="list-style-type: none"> • 3 enabling paths • 1 signaling path
Feedback	–	Feedback loop to monitor external contactors.
Safe state	–	The TM3 safety modules are in safe state when their outputs are off (internal relays are not energized; output path is open).
<p>NOTE: These modules contain electromechanical relays, so actual MTTFd and PFHd values vary depending on the application load and duty cycle.</p> <p>(1) 60 operation cycles per hour at DC-13 24 Vdc 1 A (2) 1 operation cycle per hour at DC-13 24 Vdc 4 A</p>		

Power Supply

This table describes the power supply characteristics of the TM3 safety module:

Characteristic		Value
Supply voltage	IEC 60038	24 Vdc -15...+20 %
External fuse protection (maximum)		4 A slow blow (class gG)
Power consumption	24 Vdc supply voltage	3.6 W
	TM3 Bus (5 Vdc)	0.2 W

Control Circuit

This table describes the control circuit characteristics of the TM3 safety module:

Characteristic		Value
Contact voltage	Nominal	24 Vdc
Contact current	Nominal	35 mA
	Maximum	100 mA
Response time		≤ 20 ms
Delay	On	≤ 100 ms
	Restart	≤ 300 ms

Output Circuit

This table describes the output circuit characteristics of the TM3 safety module:

Characteristic		Value
Maximum switching current of each output	AC-15: 230 Vac	5 A
	DC-13: 24 Vdc	4 A
Minimum switching voltage and current (new contact never used with higher loads)		17 V, 10 mA
Maximum current	Per output path	6 A
	Sum of current in all output paths	≤ 18 A
External fuse protection (maximum)	Slow blow (class gG) fuse	4 A
	Fast blow fuse	6 A
Maximum switching operations		$10 * 10^6$

TM3SAF5R / TM3SAF5RG Wiring Diagram

Introduction

These safety modules have a built-in removable screw or spring terminal block for the connection of inputs and outputs.

Wiring Rules

See Wiring Best Practices ([see page 53](#)).

The 24 Vdc power supply must be rated Protective Extra Low Voltage (PELV) or Safety Extra Low Voltage (SELV) and fulfill the IEC/EN 60204-1 requirements. These power supplies are isolated between the electrical input and output circuits of the power supply.

WARNING

POTENTIAL OF OVERHEATING AND FIRE

- Do not connect the equipment directly to line voltage.
- Use only isolating PELV or SELV power supplies to supply power to the equipment.

Failure to follow these instructions can result in death, serious injury, or equipment damage.

WARNING

LOSS OF CONTROL

Place a properly rated fuse on the primary input power line and on the outputs, as described in the related documentation.

Failure to follow these instructions can result in death, serious injury, or equipment damage.

Emergency Stop Wiring Diagram

Both the safety conditions and the start conditions must be valid before allowing the activation of outputs.

⚠ WARNING

UNINTENDED EQUIPMENT OPERATION

Do not use either the monitored start or the non-monitored start as a safety function.

Failure to follow these instructions can result in death, serious injury, or equipment damage.

This figure shows an example of emergency stop wiring to a TM3SAF5R• module:

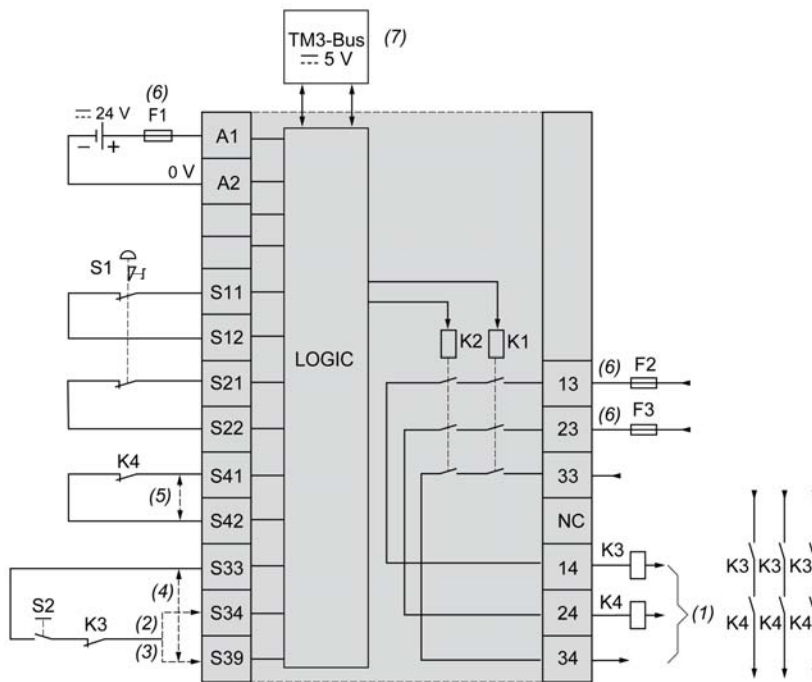

S1: Emergency stop switch

S2: Start switch

(1): Safety outputs

(2): Monitored start¹

(3): Non-monitored start¹

(4): For automatic start¹, directly connect **[S33]** and **[S39]** terminals

(5): Second external device monitoring¹ channel. Connect **[S41]** and **[S42]** terminals if not used.

(6): Fuses. Refer to electrical characteristics for fuse values.

(7): Non-safety related TM3 Bus communication with logic controller

¹ For more information, refer to the TM3 Expansion Modules Programming Guide for your software platform.

⚠ WARNING

UNINTENDED EQUIPMENT OPERATION

Do not use the data transferred over the TM3 Bus for any functional safety-related task(s).

Failure to follow these instructions can result in death, serious injury, or equipment damage.

⚠ WARNING

UNINTENDED EQUIPMENT OPERATION

Do not connect wires to unused terminals and/or terminals indicated as “No Connection (N.C.)”.

Failure to follow these instructions can result in death, serious injury, or equipment damage.

Protective Guard Wiring

This figure shows an example of 2 channel protective guard wiring to the safety module inputs:

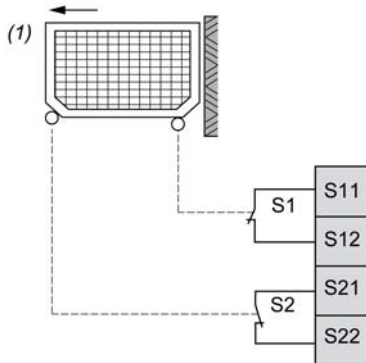

(1): Protective guard

Chapter 5

TM3SAFL5R / TM3SAFL5RG Module, 2 Functions Cat3

Overview

This chapter describes the TM3SAFL5R• module, its characteristics, and its connection.

What Is in This Chapter?

This chapter contains the following topics:

Topic	Page
TM3SAFL5R / TM3SAFL5RG Presentation	84
TM3SAFL5R / TM3SAFL5RG Characteristics	86
TM3SAFL5R / TM3SAFL5RG Wiring Diagram	90

TM3SAFL5R / TM3SAFL5RG Presentation

Overview

The main characteristics of the TM3SAFL5R (screw) and TM3SAFL5RG (spring) modules are:

- 2 channels
- 24 Vdc
- Removable screw or spring terminal

Main Characteristics

This table describes the main characteristics of the TM3SAFL5R• module:

Characteristic		Value
Number of safety input channels		2
Start mode		Monitored / Non-monitored start
Supply voltage		24 Vdc -15...+20 %
Number of outputs		3 parallel relay outputs, stop category 0
Rated output voltage		24 Vdc / 230 Vac 6 A maximum per output path
Connection type	TM3SAFL5R	Removable screw terminal block
	TM3SAFL5RG	Removable spring terminal block
Weight		190 g (6.70 oz)

Associated Applications

This table defines the type and example of applications that can be associated to the TM3SAFL5R• module:

Application type	Application example
2 channel application without short-circuit detection (<i>see page 27</i>)	<ul style="list-style-type: none"> • Monitoring 2 channel emergency stop circuits without short-circuit detection • Monitoring 2 channel limit switches on protective guards without short-circuit detection • Monitoring output signal switching devices of safety light curtains (type 4 according to IEC/EN 61496-1) with 2 * PNP transistors • Monitoring 2 * PNP transistors sensors output (proximity switches)

Status LED

This figure shows the status LEDs:

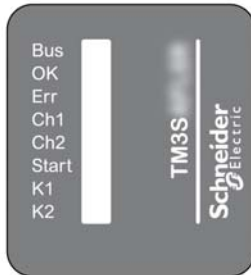

This table provides the TM3SAFL5R• module status LED indicators description:

LED	Color	Status	Description
Bus	Green	Flashing	The module is receiving the 5 Vdc power supply from the TM3 Bus and the TM3 Bus is functioning.
OK	Green	On	+24 Vdc power supply provided to the module is in the voltage tolerance.
		Flashing	TM3 Bus time-out: the functional safety operation is maintained.
Err	Red	On	+24 Vdc power supply provided to the module is out of the voltage tolerance.
		Flashing	TM3 Bus time-out: the safety output is deactivated (off).
Ch1	Green	On	Channel 1 is active: The circuit between S11-S12 is closed or supplied from OSSD output from sensor (PNP).
Ch2	Green	On	Channel 2 is active: The circuit between S21-S22 is closed or supplied from OSSD output from sensor (PNP).
Start	Green	On	Start condition valid: inputs S11-S12, S21-S22, and S41-S42 (EDM 2) closed/supplied, and S34 or S39 connected to S33.
K1	Green	On	K1 relay energized (closed)
		Flashing	Waiting for start condition
K2	Green	On	K2 relay energized (closed)
		Flashing	Waiting for start condition

TM3SAFL5R / TM3SAFL5RG Characteristics

Introduction

This section provides a description of the characteristics of TM3SAFL5R / TM3SAFL5RG safety modules.

See also Environmental Characteristics (*see page 35*).

⚠ WARNING

UNINTENDED EQUIPMENT OPERATION

Do not exceed any of the rated values specified in the environmental and electrical characteristics tables.

Failure to follow these instructions can result in death, serious injury, or equipment damage.

Dimensions

This diagram shows the external dimensions of the TM3SAFL5R / TM3SAFL5RG safety modules:

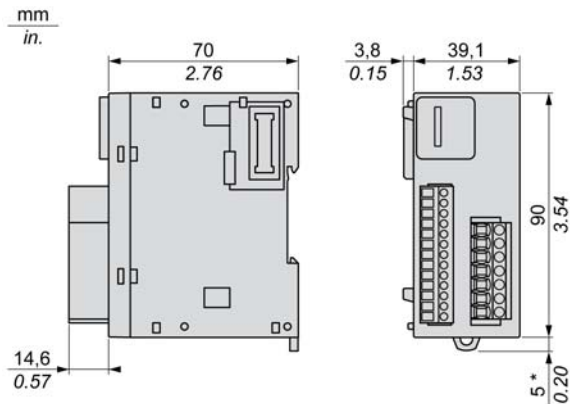

* 8.5 mm (0.33 in.) when the clamp is pulled out.

Safety-related

The TM3SAFL5R• module is a safety module for monitoring emergency stop and limit switches on protective guards and safety light curtains according to ISO/EN 13849, IEC/EN 62061, IEC/EN 61058. The module has these safety-related characteristics:

Characteristic	Designed to specification	Value
Safety integrity level (SIL)	IEC/EN 61508-1:2010	2
Safety integrity level claim limit (SILCL)	IEC/EN 62061:2005	2
Safe failure fraction (SFF)	IEC/EN 61508-1:2010	95 %
Hardware fault tolerance (HFT)	IEC/EN 61508-1:2010	1
Type	IEC/EN 61508-1:2010	A
Mode of operation	IEC/EN 61508-1:2010	High demand mode
Probability of dangerous failures per hour (PFHd)	IEC/EN 61508-1:2010	$30 \cdot 10^{-9} / \text{h}^{(1)}$
		$5 \cdot 10^{-9} / \text{h}^{(2)}$
Mean time to dangerous failure (MTTFd)	ISO/EN 13849-1:2008	85 years ⁽¹⁾
		500 years ⁽²⁾
Performance level (PL) category (cat.)	ISO/EN 13849-1:2008	PL d. cat. 3
Diagnostic coverage (DC)	ISO/EN 13849-1:2008	95 %
Lifetime	–	20 years
Response time	–	20 ms
Proof test interval (PTI)	–	None
Stop category	IEC/EN 60204-1	0
Start	–	Manual or automatic
Paths	–	<ul style="list-style-type: none"> • 3 enabling paths • 1 signaling path
Feedback	–	Feedback loop to monitor external contactors.
Safe state	–	The TM3 safety modules are in safe state when their outputs are off (internal relays are not energized; output path is open).
<p>NOTE: These modules contain electromechanical relays, so actual MTTFd and PFHd values vary depending on the application load and duty cycle.</p> <p>(1) 60 operation cycles per hour at DC-13 24 Vdc 1 A (2) 1 operation cycle per hour at DC-13 24 Vdc 4 A</p>		

Power Supply

This table describes the power supply characteristics of the TM3 safety module:

Characteristic		Value
Supply voltage	IEC 60038	24 Vdc -15...+20 %
External fuse protection (maximum)		4 A slow blow (class gG)
Power consumption	24 Vdc supply voltage	3.6 W
	TM3 Bus (5 Vdc)	0.2 W

Control Circuit

This table describes the control circuit characteristics of the TM3 safety module:

Characteristic		Value
Input voltage (high) ⁽¹⁾	Minimum	19.6 Vdc
	Nominal	24 Vdc
	Maximum	28.8 Vdc
Input voltage (low) ⁽¹⁾	Minimum	0 Vdc
	Nominal	0 Vdc
	Maximum	2 Vdc
Input current (high) ⁽¹⁾	Nominal	35 mA
	Maximum	80 mA
Input current (low) ⁽¹⁾	Nominal	0 mA
Maximum output current from control circuit terminals: S11, S22 (see page 17)		100 mA
Nominal voltage at the pins		24 Vdc
Response time		≤ 20 ms
Delay	On	≤ 100 ms
	Restart	≤ 300 ms
(1) At terminal S12, S22 when externally supplied		

Output Circuit

This table describes the output circuit characteristics of the TM3 safety module:

Characteristic		Value
Maximum switching current of each output	AC-15: 230 Vac	5 A
	DC-13: 24 Vdc	4 A
Minimum switching voltage and current (new contact never used with higher loads)		17 V, 10 mA
Maximum current	Per output path	6 A
	Sum of current in all output paths	≤ 18 A
External fuse protection (maximum)	Slow blow (class gG) fuse	4 A
	Fast blow fuse	6 A
Maximum switching operations		$10 * 10^6$

TM3SAFL5R / TM3SAFL5RG Wiring Diagram

Introduction

These safety modules have a built-in removable screw or spring terminal block for the connection of inputs and outputs.

Wiring Rules

See Wiring Best Practices ([see page 53](#)).

The 24 Vdc power supply must be rated Protective Extra Low Voltage (PELV) or Safety Extra Low Voltage (SELV) and fulfill the IEC/EN 60204-1 requirements. These power supplies are isolated between the electrical input and output circuits of the power supply.

WARNING

POTENTIAL OF OVERHEATING AND FIRE

- Do not connect the equipment directly to line voltage.
- Use only isolating PELV or SELV power supplies to supply power to the equipment.

Failure to follow these instructions can result in death, serious injury, or equipment damage.

WARNING

LOSS OF CONTROL

Place a properly rated fuse on the primary input power line and on the outputs, as described in the related documentation.

Failure to follow these instructions can result in death, serious injury, or equipment damage.

Emergency Stop Wiring Diagram

Both the safety conditions and the start conditions must be valid before allowing the activation of outputs.

⚠ WARNING

UNINTENDED EQUIPMENT OPERATION

Do not use either the monitored start or the non-monitored start as a safety function.

Failure to follow these instructions can result in death, serious injury, or equipment damage.

This figure shows an example of emergency stop wiring to a TM3SAFL5R• module:

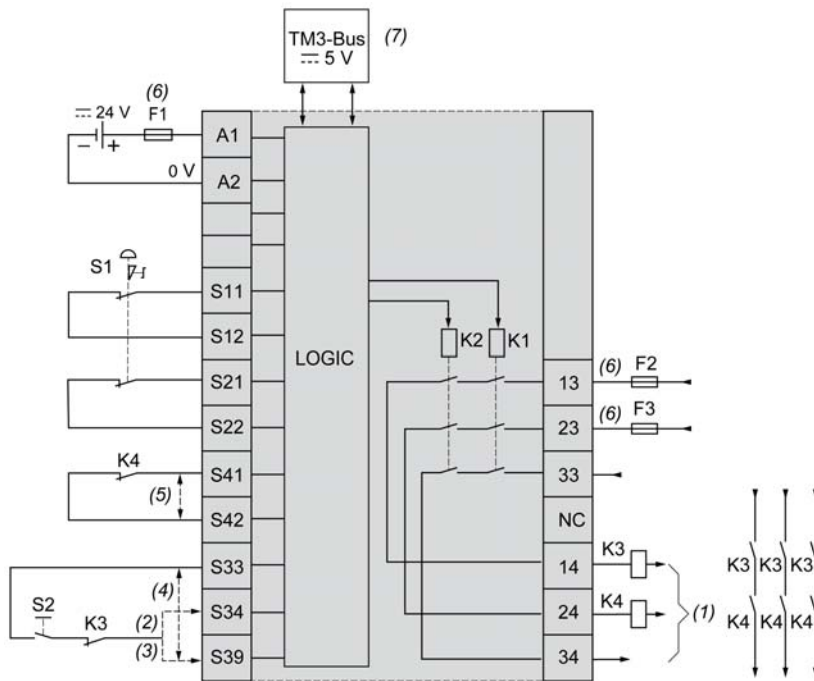

S1: Emergency stop switch

S2: Start switch

(1): Safety outputs

(2): Monitored start¹

(3): Non-monitored start¹

(4): For automatic start¹, directly connect **[S33]** and **[S39]** terminals

(5): Second external device monitoring¹ channel. Connect **[S41]** and **[S42]** terminals if not used.

(6): Fuses. Refer to electrical characteristics for fuse values.

(7): Non-safety related TM3 Bus communication with logic controller

¹ For more information, refer to the TM3 Expansion Modules Programming Guide for your software platform.

⚠ WARNING

UNINTENDED EQUIPMENT OPERATION

Do not use the data transferred over the TM3 Bus for any functional safety-related task(s).

Failure to follow these instructions can result in death, serious injury, or equipment damage.

⚠ WARNING

UNINTENDED EQUIPMENT OPERATION

Do not connect wires to unused terminals and/or terminals indicated as “No Connection (N.C.)”.

Failure to follow these instructions can result in death, serious injury, or equipment damage.

Protective Guard Wiring

This figure shows an example of 2 channel protective guard wiring to the safety module inputs:

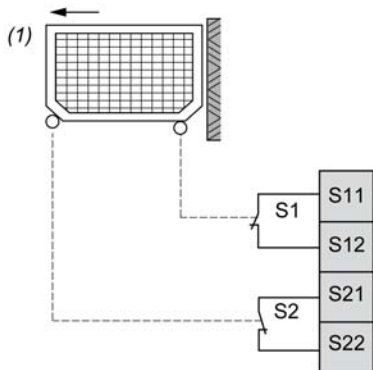

(1): Protective guard

Electro-Sensitive Protective Equipment (ESPE) Wiring

This figure shows an example of ESPE (type 4 outputs, IEC/EN 61496-1) wiring to the safety module inputs:

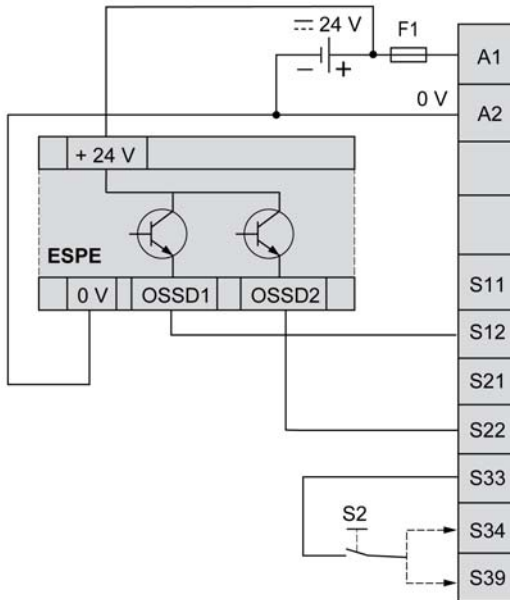

S2: Start switch

NOTE: The ESPE must be supplied by the same PELV/SELV power supply as the safety module.

Chapter 6

TM3SAK6R / TM3SAK6RG Module, 3 Functions Cat4

Overview

This chapter describes the TM3SAK6R• module, its characteristics, and its connection.

What Is in This Chapter?

This chapter contains the following topics:

Topic	Page
TM3SAK6R / TM3SAK6RG Presentation	96
TM3SAK6R / TM3SAK6RG Characteristics	99
TM3SAK6R / TM3SAK6RG Wiring Diagram	103

TM3SAK6R / TM3SAK6RG Presentation

Overview

The main characteristics of the TM3SAK6R (screw) and TM3SAK6RG (spring) modules are:

- 2 channels
- 24 Vdc
- Removable screw or spring terminal

Main Characteristics

This table describes the main characteristics of the TM3SAK6R• module:

Characteristic		Value
Number of safety input channels		2
Start mode		Monitored / Non-monitored start
Supply voltage		24 Vdc -15...+20 %
Number of outputs		3 parallel relay outputs, stop category 0
Rated output voltage		24 Vdc / 230 Vac 6 A maximum per output path
Connection type	TM3SAK6R	Removable screw terminal block
	TM3SAK6RG	Removable spring terminal block
Weight		190 g (6.70 oz)

Associated Applications

This table defines the type and example of applications that can be associated to the TM3SAK6R• module:

Application type	Application example
1 channel application (see page 24)	<ul style="list-style-type: none"> • Monitoring 1 channel emergency stop circuits • Monitoring 1 channel limit switches on protective guards
2 channel application (see page 27) without short-circuit detection	<ul style="list-style-type: none"> • Monitoring 2 channel emergency stop circuits without short-circuit detection • Monitoring 2 channel limit switches on protective guards without short-circuit detection • Monitoring output signal switching devices of safety light curtains (type 4 according to IEC/EN 61496-1) with 2 * PNP transistors • Monitoring 2 * PNP transistors sensors output (proximity switches)

Application type	Application example
2 channel application (see page 27) with short-circuit detection	<ul style="list-style-type: none"> Monitoring 2 channel emergency stop circuits with short-circuits detection Monitoring 2 channel limit switches on protective guards with short-circuit detection Monitoring output signal switching devices of safety light curtains (type 4 according to IEC/EN 61496-1) with 1 PNP + 1 NPN transistors Monitoring 1 PNP + 1 NPN transistors sensors output (proximity switches)
Safety-mat application (see page 31) (current source)	<ul style="list-style-type: none"> Monitoring short-circuit generating safety-mats or pressure sensitive rails

Synchronization Time Monitoring

Synchronization time between activation of inputs S21-S22 and S31-S32 can be monitored either within 2 or 4 seconds.

For additional information, refer to the TM3 Expansion Modules Programming Guide for your software platform.

Status LED

This figure shows the status LEDs:

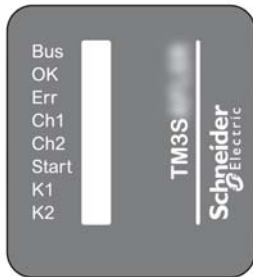

This table provides the TM3SAK6R• module status LED indicators description:

LED	Color	Status	Description
Bus	Green	Flashing	The module is receiving the 5 Vdc power supply from the TM3 Bus and the TM3 Bus is functioning.
OK	Green	On	+24 Vdc power supply provided to the module is in the voltage tolerance.
		Flashing	TM3 Bus time-out: the functional safety operation is maintained.
Err	Red	On	+24 Vdc power supply provided to the module is out of the voltage tolerance.
		Flashing	TM3 Bus time-out: the safety output is deactivated (off).

LED	Color	Status	Description
Ch1	Green	On	Depending on the application. See next table.
		Flashing	Synchronization time monitoring detected an error: input S21-S22 closed too late after input S31-S32.
Ch2	Green	On	Depending on the application. See next table.
		Flashing	Synchronization time monitoring detected an error: input S31-S32 closed too late after input S21-S22. See note below.
Start	Green	On	Start condition valid: inputs S11-S12, S21-S22, S31-S32, and S41-S42 (EDM 2) closed/supplied, and S34 or S39 connected to S33. See note below.
K1	Green	On	K1 relay energized (closed)
		Flashing	Waiting for start condition
K2	Green	On	K2 relay energized (closed)
		Flashing	Waiting for start condition

This table gives information on **Ch1** and **Ch2** status:

Use case	Channel	Condition
1-channel application (cat. 1)	Ch1	Input S11-S12 closed and input S31-S32 closed with a jumper.
	Ch2	Input S21-S22 closed with a jumper.
2-channel application (cat. 3 - w/o short-circuit monitoring)	Ch1	Input S11-S12 and input S31-S32 closed.
	Ch2	Input S21-S22 closed with a jumper.
2-channel application (cat. 4)	Ch1	Input S11-S12 closed and input S31-S32 closed with a jumper.
	Ch2	Input S21-S22 closed.
2-channel application (cat. 3 - if the sensor device can detect short-circuit, then cat. 4) Solid state: PNP + PNP	Ch1	Input S12 and input S32 supplied with PNP 24 V connection.
	Ch2	Input S21-S22 closed with a jumper.
2-channel application (cat. 4) Solid state: PNP + NPN	Ch1	Input S11-S12 closed with a jumper and input S32 supplied with PNP 24 V connection.
	Ch2	Input S22 connected to external NPN 0 V.
Safety mat application	Ch1	Input S11-S12 closed by jumper, with safety mat connected to input S31-S32.
	Ch2	Safety mat connected to input S21-S22.

NOTE: While waiting for Start there is no indication of **Ch2** if S41-S42 (EDM 2) is open (by feedback of external device (NC contact)).

TM3SAK6R / TM3SAK6RG Characteristics

Introduction

This section provides a description of the characteristics of TM3SAK6R / TM3SAK6RG safety modules.

See also Environmental Characteristics (*see page 35*).

WARNING

UNINTENDED EQUIPMENT OPERATION

Do not exceed any of the rated values specified in the environmental and electrical characteristics tables.

Failure to follow these instructions can result in death, serious injury, or equipment damage.

Dimensions

This diagram shows the external dimensions of the TM3SAK6R / TM3SAK6RG safety modules:

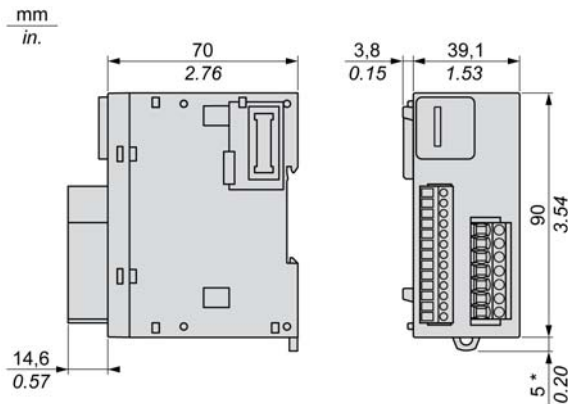

* 8.5 mm (0.33 in.) when the clamp is pulled out.

Safety-related

The TM3SAK6R• module is a safety module for monitoring emergency stop and limit switches on protective guards, safety light curtains, and safety-mats according to ISO/EN 13849, IEC/EN 62061, IEC/EN 61058. The module has these safety-related characteristics:

Characteristic	Designed to specification	Value
Safety integrity level (SIL)	IEC/EN 61508-1:2010	3
Safety integrity level claim limit (SILCL)	IEC/EN 62061:2005	3
Safe failure fraction (SFF)	IEC/EN 61508-1:2010	95 %
Hardware fault tolerance (HFT)	IEC/EN 61508-1:2010	1
Type	IEC/EN 61508-1:2010	A
Mode of operation	IEC/EN 61508-1:2010	High demand mode
Probability of dangerous failures per hour (PFHd)	IEC/EN 61508-1:2010	$30 * 10^{-9} / h^{(1)}$
		$5 * 10^{-9} / h^{(2)}$
Mean time to dangerous failure (MTTFd)	ISO/EN 13849-1:2008	85 years ⁽¹⁾
		500 years ⁽²⁾
Performance level (PL) category (cat.)	ISO/EN 13849-1:2008	PL e. cat. 4
Diagnostic coverage (DC)	ISO/EN 13849-1:2008	95 %
Lifetime	–	20 years
Response time	–	20 ms
Proof test interval (PTI)	–	None
Stop category	IEC/EN 60204-1	0
Start	–	Manual or automatic
Paths	–	<ul style="list-style-type: none"> • 3 enabling paths • 1 signaling path
Feedback	–	Feedback loop to monitor external contactors.
Safe state	–	The TM3 safety modules are in safe state when their outputs are off (internal relays are not energized; output path is open).
<p>NOTE: These modules contain electromechanical relays, so actual MTTFd and PFHd values vary depending on the application load and duty cycle.</p> <p>(1) 60 operation cycles per hour at DC-13 24 Vdc 1 A</p> <p>(2) 1 operation cycle per hour at DC-13 24 Vdc 4 A</p>		

Power Supply

This table describes the power supply characteristics of the TM3 safety module:

Characteristic		Value
Supply voltage	IEC 60038	24 Vdc -15...+20 %
External fuse protection (maximum)		4 A slow blow (class gG)
Power consumption	24 Vdc supply voltage	3.6 W
	TM3 Bus (5 Vdc)	0.2 W

Control Circuit

This table describes the control circuit characteristics of the TM3 safety module:

Characteristic		Value
Input voltage (high) ⁽¹⁾	Minimum	19.6 Vdc
	Nominal	24 Vdc
	Maximum	28.8 Vdc
Input voltage (low) ⁽¹⁾	Minimum	0 Vdc
	Nominal	0 Vdc
	Maximum	2 Vdc
Input current (high) ⁽¹⁾	Nominal	35 mA
	Maximum	80 mA
Input current (low) ⁽¹⁾	Nominal	0 mA
Maximum output current from control circuit terminals: S11, S31, S22 (see page 17)		100 mA
Nominal voltage at the pins		24 Vdc
Response time		≤ 20 ms
Delay	On	≤ 100 ms
	Restart	≤ 300 ms
(1) At terminal S12, S32 when externally supplied		

Output Circuit

This table describes the output circuit characteristics of the TM3 safety module:

Characteristic		Value
Maximum switching current of each output	AC-15: 230 Vac	5 A
	DC-13: 24 Vdc	4 A
Minimum switching voltage and current (new contact never used with higher loads)		17 V, 10 mA
Maximum current	Per output path	6 A
	Sum of current in all output paths	≤ 18 A
External fuse protection (maximum)	Slow blow (class gG) fuse	4 A
	Fast blow fuse	6 A
Maximum switching operations		$10 * 10^6$

TM3SAK6R / TM3SAK6RG Wiring Diagram

Introduction

These safety modules have a built-in removable screw or spring terminal block for the connection of inputs and outputs.

Wiring Rules

See Wiring Best Practices ([see page 53](#)).

The 24 Vdc power supply must be rated Protective Extra Low Voltage (PELV) or Safety Extra Low Voltage (SELV) and fulfill the IEC/EN 60204-1 requirements. These power supplies are isolated between the electrical input and output circuits of the power supply.

WARNING

POTENTIAL OF OVERHEATING AND FIRE

- Do not connect the equipment directly to line voltage.
- Use only isolating PELV or SELV power supplies to supply power to the equipment.

Failure to follow these instructions can result in death, serious injury, or equipment damage.

WARNING

LOSS OF CONTROL

Place a properly rated fuse on the primary input power line and on the outputs, as described in the related documentation.

Failure to follow these instructions can result in death, serious injury, or equipment damage.

Emergency Stop Wiring Diagram

Both the safety conditions and the start conditions must be valid before allowing the activation of outputs.

 **WARNING**

UNINTENDED EQUIPMENT OPERATION

Do not use either the monitored start or the non-monitored start as a safety function.

Failure to follow these instructions can result in death, serious injury, or equipment damage.

This figure shows an example of emergency stop wiring to a TM3SAK6R• module:

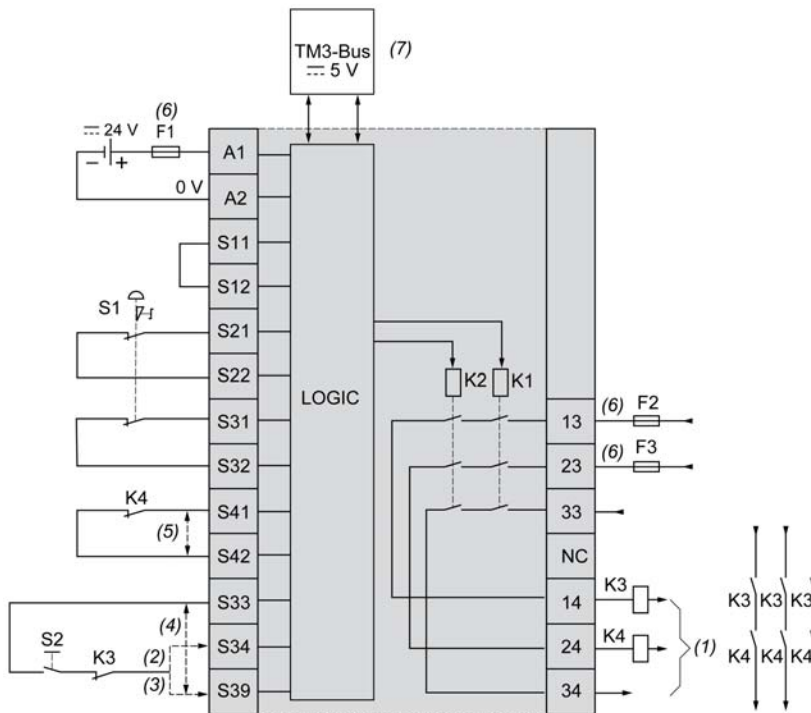

- S1:** Emergency stop switch
- S2:** Start switch
- (1): Safety outputs
- (2): Monitored start¹
- (3): Non-monitored start¹
- (4): For automatic start¹, directly connect [S33] and [S39] terminals

- (5): Second external device monitoring¹ channel. Connect [S41] and [S42] terminals if not used.
- (6): Fuses. Refer to electrical characteristics for fuse values.
- (7): Non-safety related TM3 Bus communication with logic controller

¹ For more information, refer to the TM3 Expansion Modules Programming Guide for your software platform.

⚠ WARNING
UNINTENDED EQUIPMENT OPERATION
Do not use the data transferred over the TM3 Bus for any functional safety-related task(s).
Failure to follow these instructions can result in death, serious injury, or equipment damage.

⚠ WARNING
UNINTENDED EQUIPMENT OPERATION
Do not connect wires to unused terminals and/or terminals indicated as “No Connection (N.C.)”.
Failure to follow these instructions can result in death, serious injury, or equipment damage.

Protective Guard Wiring

This figure shows an example of 2 channel protective guard wiring to the safety module inputs:

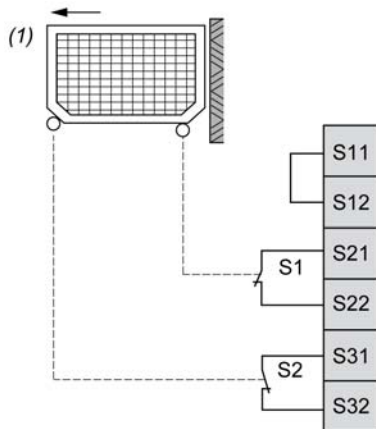

(1): Protective guard

Safety-Mat Wiring

This figure shows an example of safety-mat (pressure sensitive, short circuit generating) wiring to the safety module inputs:

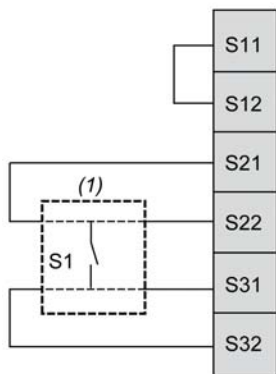

(1): Safety-mat

NOTE: Normally, most safety-mats are maladapted for use in combination with the automatic start mode. In addition, if you use the safety-mat in your application which includes the automatic start mode, you should consider this in your risk analysis.

⚠ WARNING

UNINTENDED EQUIPMENT OPERATION

Only use short-circuit generating pressure sensitive devices according to ISO/EN 13856-1:2013 for the safety-mat function.

Failure to follow these instructions can result in death, serious injury, or equipment damage.

One Channel Emergency Stop Wiring

This figure illustrates an example of 1 channel emergency stop wiring to the safety module inputs:

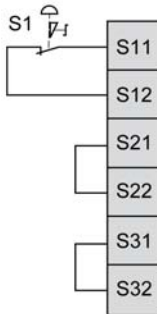

S1: Emergency stop switch

Two Channel Emergency Stop Wiring

This figure illustrates two examples of 2 channel emergency stop wiring to the safety module inputs:

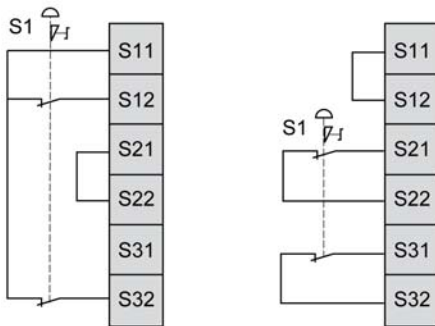

S1: Emergency stop switch

NOTE: Inputs **S11** and **S12** are not intended for the monitoring of short-circuits in external wiring.

⚠ WARNING

UNINTENDED EQUIPMENT OPERATION

Do not use the **S11** and **S12** inputs to build SIL 3 applications unless you exclude the possibility of short-circuits by external measures.

Failure to follow these instructions can result in death, serious injury, or equipment damage.

Electro-Sensitive Protective Equipment (ESPE) Wiring

This figure shows an example of ESPE (type 4 outputs, IEC/EN 61496-1) wiring to the safety module inputs:

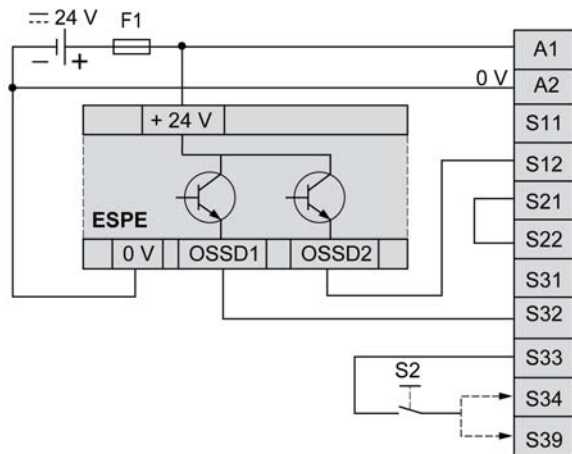

S2: Start switch

NOTE: The ESPE must be supplied by the same PELV/SELV power supply as the safety module.

Proximity Sensors Without Short Circuit Detection Wiring

This figure shows an example of a 2 channel application (2 * PNP sensors) wiring to the safety module inputs:

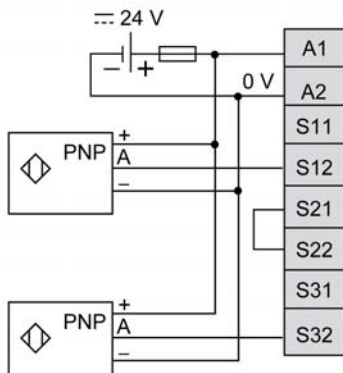

NOTE: The sensors must be supplied by the same PELV/SELV power supply as the safety module.

Proximity Sensors with Short Circuit Detection Wiring

This figure shows an example of a 2 channel application (PNP + NPN complementary sensors) wiring to the safety module inputs:

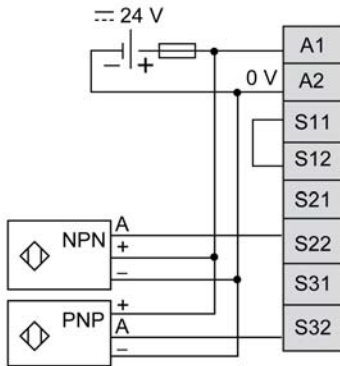

NOTE: The sensors must be supplied by the same PELV/SELV power supply as the safety module.



E

EIA rack

(*electronic industries alliance rack*) A standardized (EIA 310-D, IEC 60297, and DIN 41494 SC48D) system for mounting various electronic modules in a stack or rack that is 19 inches (482.6 mm) wide.

EN

EN identifies one of many European standards maintained by CEN (*European Committee for Standardization*), CENELEC (*European Committee for Electrotechnical Standardization*), or ETSI (*European Telecommunications Standards Institute*).

expansion connector

A connector to attach expansion I/O modules.

F

FE

(*functional Earth*) A common grounding connection to enhance or otherwise allow normal operation of electrically sensitive equipment (also referred to as functional ground in North America).

In contrast to a protective Earth (protective ground), a functional earth connection serves a purpose other than shock protection, and may normally carry current. Examples of devices that use functional earth connections include surge suppressors and electromagnetic interference filters, certain antennas, and measurement instruments.

I

IEC

(*international electrotechnical commission*) A non-profit and non-governmental international standards organization that prepares and publishes international standards for electrical, electronic, and related technologies.

IP 20

(*ingress protection*) The protection classification according to IEC 60529 offered by an enclosure, shown by the letter IP and 2 digits. The first digit indicates 2 factors: helping protect persons and for equipment. The second digit indicates helping protect against water. IP 20 devices help protect against electric contact of objects larger than 12.5 mm, but not against water.

N

NEMA

(national electrical manufacturers association) The standard for the performance of various classes of electrical enclosures. The NEMA standards cover corrosion resistance, ability to help protect from rain, submersion, and so on. For IEC member countries, the IEC 60529 standard classifies the ingress protection rating for enclosures.



A

- accessories, 16
- application
 - TM3SAC5R, 64
 - TM3SAC5RG, 64
 - TM3SAF5R, 74
 - TM3SAF5RG, 74
 - TM3SAFL5R, 84
 - TM3SAFL5RG, 84
 - TM3SAK6R, 96
 - TM3SAK6RG, 96
- assembling to a controller, 48

C

- certifications and standards, 38
- controllers
 - disassembling a module, 50

E

- environmental characteristics, 35

I

- inductive load
 - output protection, 57

M

- minimum clearances, 43
- module, 16
- mounting position, 43

O

- output protection
 - inductive load, 57

P

- physical description
 - TM3 safety module, 21
- power supply, 59

T

- TM3 safety module
 - physical description, 21
- TM3SAC5R, 63
 - application, 64
 - wiring diagram, 69
- TM3SAC5RG, 63
 - application, 64
 - wiring diagram, 69
- TM3SAF5R, 73
 - application, 74
 - wiring diagram, 79
- TM3SAF5RG, 73
 - application, 74
 - wiring diagram, 79
- TM3SAFL5R, 83
 - application, 84
 - wiring diagram, 90
- TM3SAFL5RG, 83
 - application, 84
 - wiring diagram, 90
- TM3SAK6R, 95
 - application, 96
 - wiring diagram, 103
- TM3SAK6RG, 95
 - application, 96
 - wiring diagram, 103

W

wiring diagram

TM3SAC5R, 69

TM3SAC5RG, 69

TM3SAF5R, 79

TM3SAF5RG, 79

TM3SAFL5R, 90

TM3SAFL5RG, 90

TM3SAK6R, 103

TM3SAK6RG, 103

wiring rules, 53